



2023 Real Leather UK

| **FOOTWEAR DESIGN** |

LYNN KWAK
(GYOUNGRYOUNG KWAK)

MOMENTS THROUGH THE WINDOW



This project was inspired by the moments through the window. The moments seen through the window are fleeting. I want to capture that moment to 'save' it. Nature, Windows, and memories Preserved are the key concept for the designs.



PROJECT STORY

The moments seen through the window are fleeting. The sky and the trees are always there, but the seasons change, and with the passage of time comes change. I want to 'save' those moments as if I were taking them with a camera.

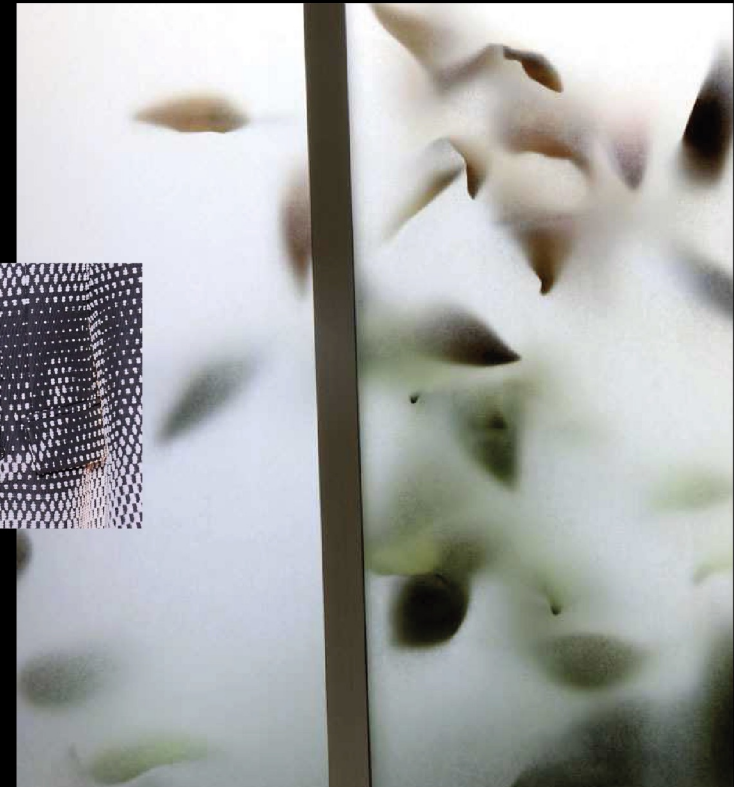
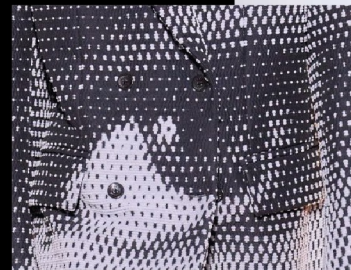

SAVEING

Preserved the Moment

The window - a frame of a famous artist's painting

Artist Research

Alejandro Almanza Pereda



In his work, the painting is hanging on the wall and a chunk of concrete is stuck on top of it. The result of spraying liquid concrete emphasize the construction absorbing the painting. From his work I get the idea of spray and concrete to for absorbing.



Alejandro Almanza Pereda



STRUCTURE



The structural elements of the window can be used for the upper design and overlay with various fabric and leather materials to express a view from the window.



Design Detail Research



Inspired by the **mountains** I saw through the window. I wanted the **sole** to have the texture of a stone mountain to give the impression of someone stepping on it.

Sulpture Texture Sole Research

ROCK - Sculpture
SNOW - Salt

D3 sole development



3D

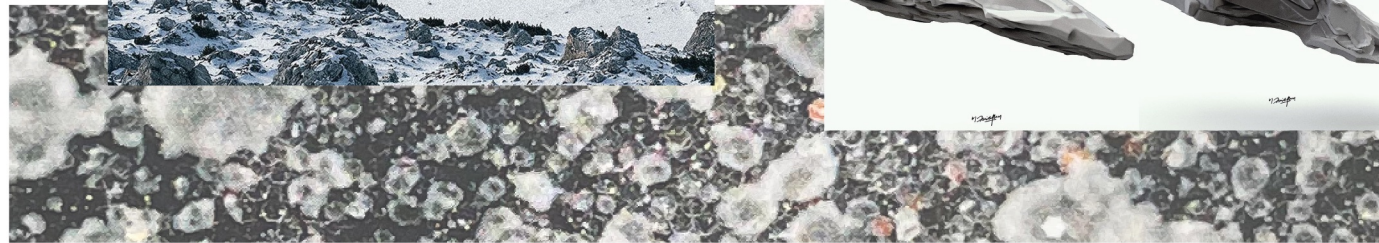

Salt helps preserve things. Like Sigalit's pickled shoes from Dead Sea, **salt** could use as **a shoe ornament**.

Salt years
Sigalit Landau

If I use salt as 'desintic', it can replace to jewellery such as Swarovski crystals to your clothes or shoes. However, jewellery can not capture the purity of the colour that come from nature, so I decided to use the salt itself.

MOOD BOARD



Theme in three things:
Windows, Frames,
and **memories preserved.**

Based on the Pantone 2023 colour of the year, the colour chips inspired from nature. The nature projected on the window gives soothing atmosphere, therefore the colours were chosen with greyish hues.

COLOUR PALETTE



NATURAL MATERIALS

KEY TEXTURES



LEAVES

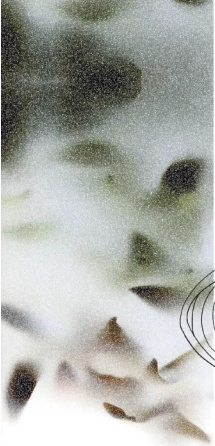

WINDOW

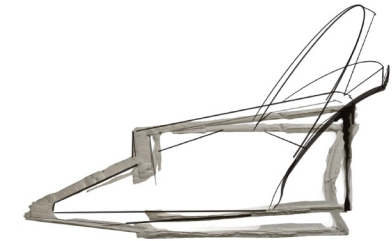
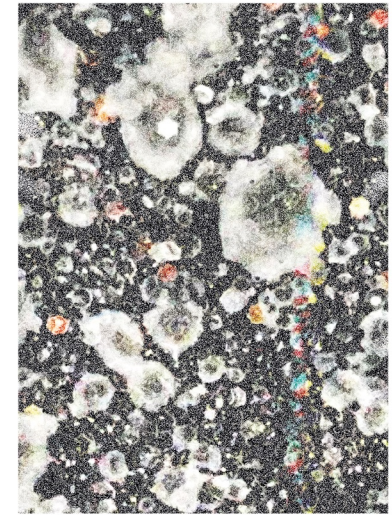
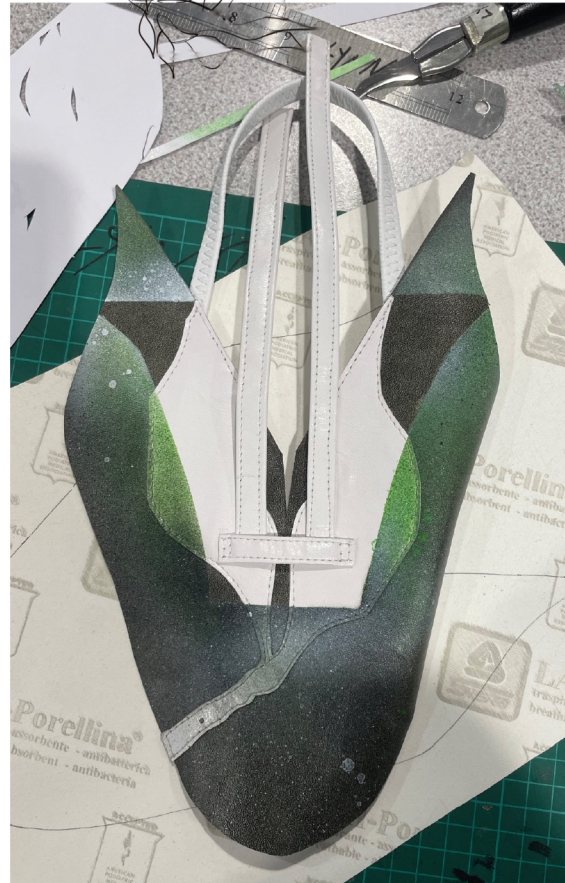
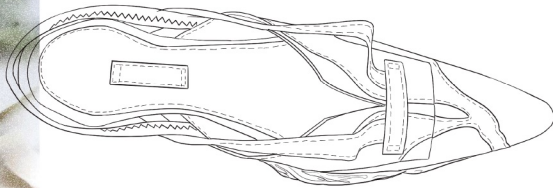
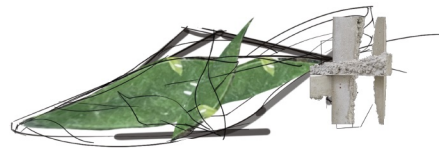

CONCRETE
TEXTURE



DESIGN PROCESS

D1 - SEASONS OF THE TREE

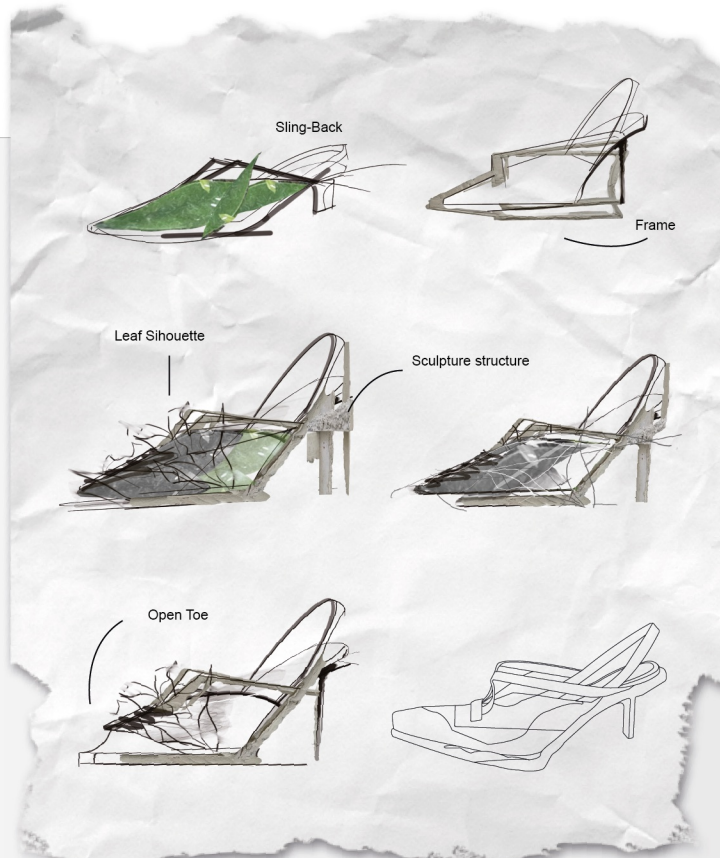

D2 - SNOW MOUNTAIN

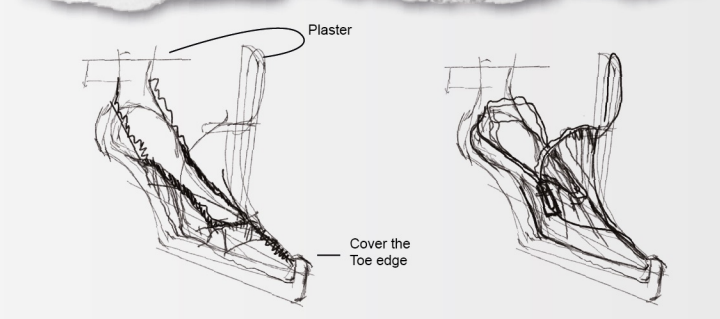

DESIGN PROCESS

DESIGN 3 - CONCRETE

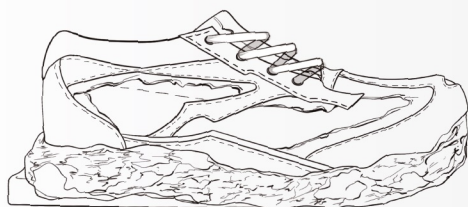

RENDERING



3D PROTOTYPE



FINAL RENDERING

MOMENTS THROUGH THE WINDOW



FINAL COLLECTION



MOMENTS
THROUGH
THE WINDOW



MOMENTS
THROUGH
THE WINDOW







STYLE: *Women Shoe*
 NUMBER: *1*

CATEGORY: *Salt*
 MANAGER: *Lynn Kwak*

WATERPROOF: *x*
 i SvHIELD:

PAGE

DESIGNER:
 DEVELOPER:

PREVIOUS NAME & NUMBER: *D 1*

SIZE / GENDER: *UK 4 / Women*

DATE OF ISSUE: *30/04/2023*

INLINE - [REDACTED]

TARGET PRICE - *£ 1000*

D1 Upper

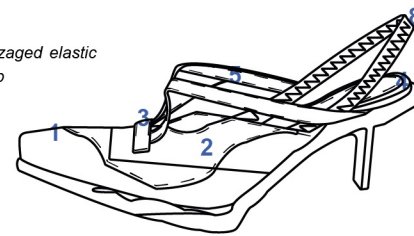
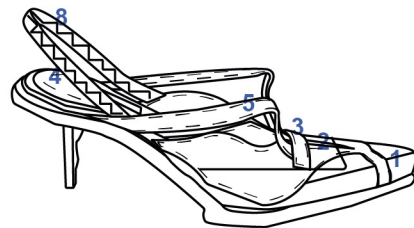
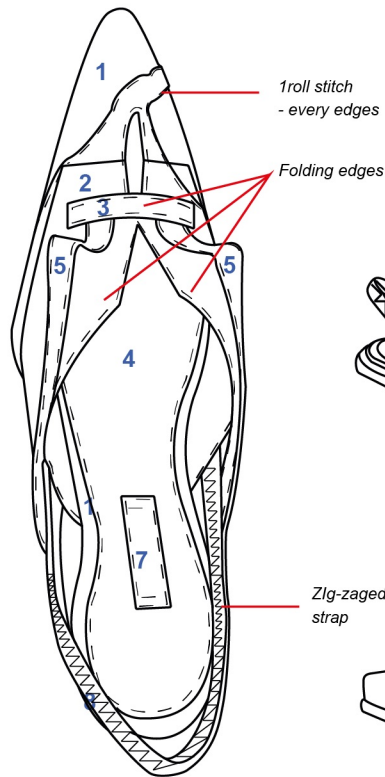

Sole Material & Texture



Rock (Plaster + Cement)
 Colour : White, Grey, Black

Details

Toe Part



1

Sprayed dark green leather



PANTONE®
14-5002
Silver



PANTONE®
17-0615
Oil Green

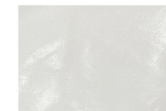

2

White glossy leather



PANTONE®
11-6001 TPC
Brilliant White

Upper Detail



3, 5

White glossy leather
hand made strap



PANTONE®
11-6001 TPC
Brilliant White

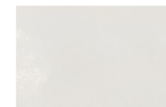

4

Synthetic white for lining



PANTONE®
11-6001 TPC
Brilliant White

Strap Detail



7

Logo - Spray abstractly
on the dark green leather



PANTONE®
17-5104 TCK
Ultimate Gray



8

Zig-Zaged white elastic strap



PANTONE®
11-6001 TPC
Brilliant White

Edges

1 raw - 60 white thread - - - - -
 Thread colours are depend on the leather
 (same colour with leather) - White, Grey, Dark green



STYLE: *Women Shoe*
NUMBER: *1*

CATEGORY: *Salt*
MANAGER: *Lynn Kwak*

WATERPROOF: *x*
i SvHIELD:

PAGE

DESIGNER:
DEVELOPER:

PREVIOUS NAME & NUMBER: *D 1*

SIZE / GENDER: *UK 4/ Women*

DATE OF ISSUE: *30/04/2023*

INLINE -

TARGET PRICE - *£ 1000*

D1 Upper & Sole

Side view - Right side

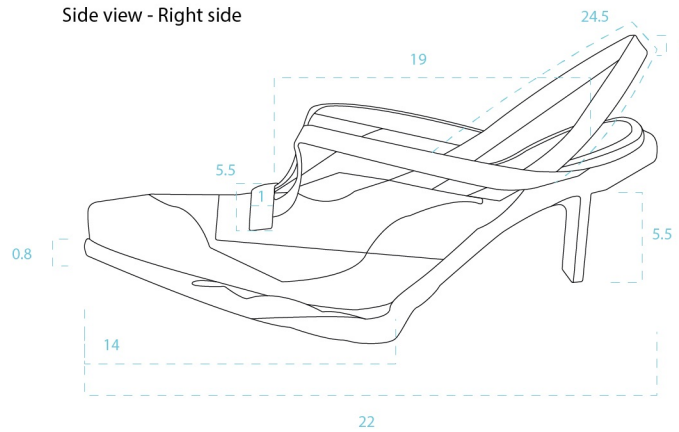

Sole part

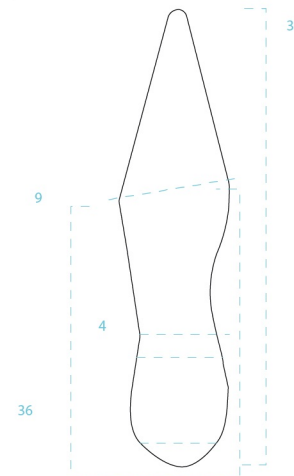

Top view

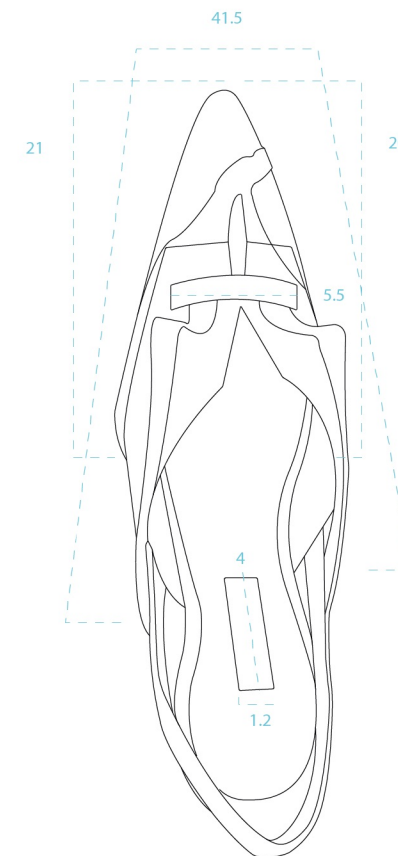

Side view - Left side

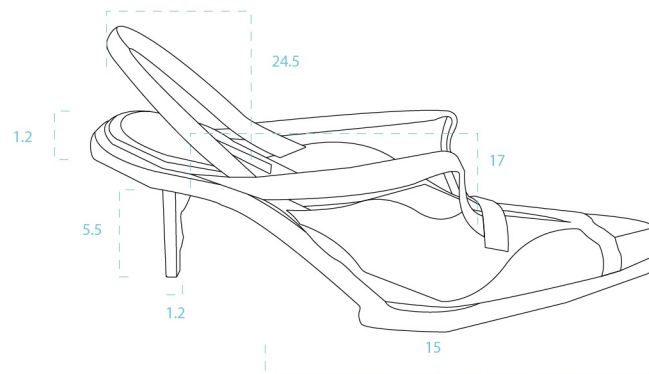

Back view

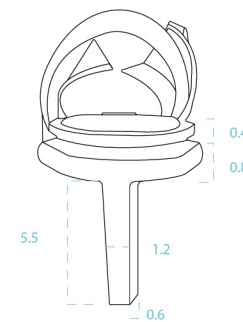



STYLE: <i>Women Shoe</i>	CATEGORY: <i>Salt</i>	WATERPROOF: <i>x</i>	PAGE	DESIGNER:
NUMBER: <i>1</i>	MANAGER: <i>Lynn Kwak</i>	i SvHIELD:		DEVELOPER:
PREVIOUS NAME & NUMBER: <i>D 1</i>	SIZE / GENDER: <i>UK 4 / Women</i>	DATE OF ISSUE: <i>30/04/2023</i>	INLINE - 	TARGET PRICE - <i>£ 1000</i>

D2

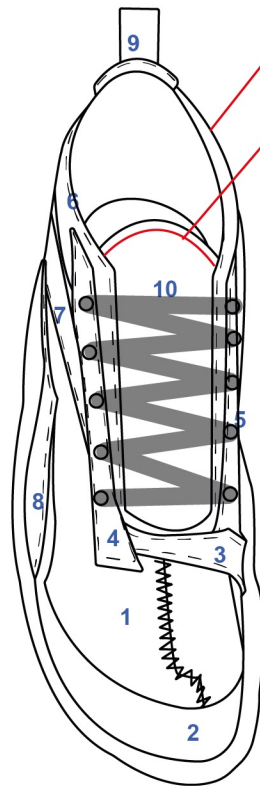

1 roll stitches around all edges

Bagged edge



Logo - Insole



Logo - Spray abstractly on the dark green leather

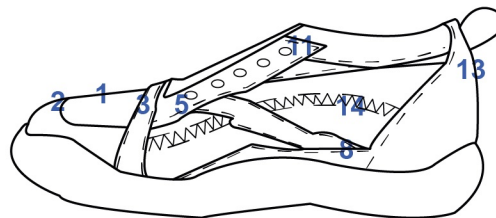
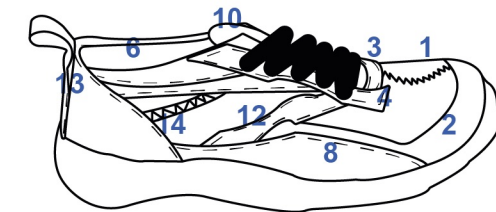

Details

Toe Part

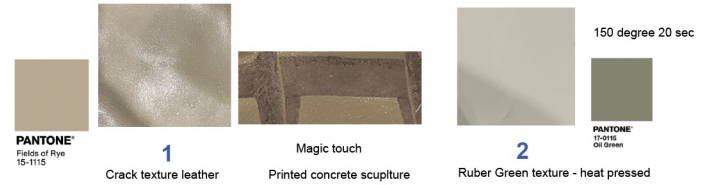

Upper Detail

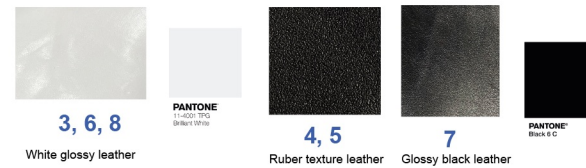

Heel, Detail

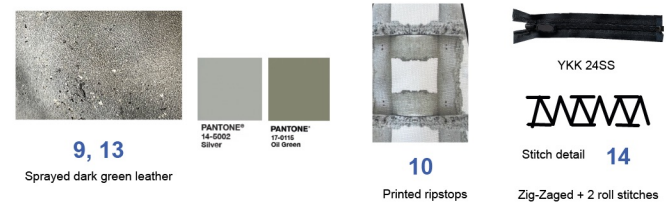

Edges

1 row - 60 white, Grey thread - - - - - 11 Shoe lace holes - 0.6 raw edges
 Thread colours are depend on the leather
 (same colour with leather) - White, Grey, Dark green, Black



STYLE: NUMBER:	Women Shoe 1	CATEGORY: MANAGER:	Salt Lynn Kwak	WATERPROOF: i SvHIELD:	x	PAGE	DESIGNER: DEVELOPER:
PREVIOUS NAME & NUMBER:	D 1	SIZE / GENDER:	UK 4 / Women	DATE OF ISSUE:	30/04/2023	INLINE - 	TARGET PRICE - £ 1000

D3

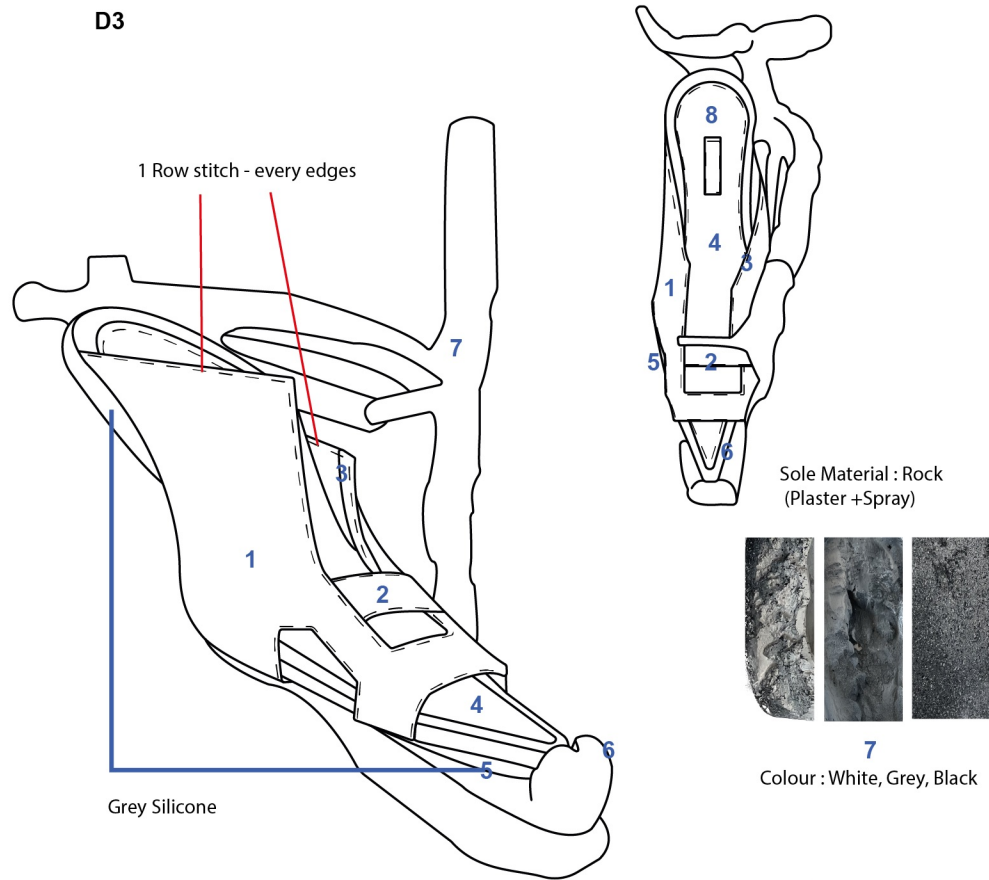

Details

Upper Part

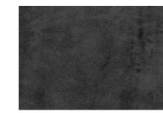

1
Black suede

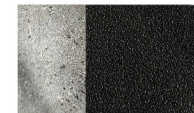

2
Ruber texture leather - Sprayed fade out white



PANTONE
Black 6 C

Upper Detail



3
Sprayed dark green leather



PANTONE®
14-5002
Silver



PANTONE®
15-0115
Oil Green



4
Synthetic white for lining



PANTONE
Black 9 C

Heel, Detail



5
Grey silicone sole



PANTONE®
14-5002
Silver

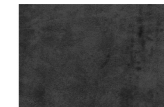

6
Black suede



PANTONE®
Black 9 C



8
Logo - Spray abstractly
on the dark green leather

Edges

1 row - 60 white, Grey thread - - - - -
Thread colours are depend on the leather
(opposite colour with leather) - White, Grey, Dark green, Black



STYLE: *Women Shoe*
NUMBER: *1*

CATEGORY: *Salt*
MANAGER: *Lynn Kwak*

WATERPROOF: *x*
i SvHIELD:

PAGE

DESIGNER:
DEVELOPER:

PREVIOUS NAME & NUMBER: *D 1*

SIZE / GENDER: *UK 4 / Women*

DATE OF ISSUE: *30/04/2023*

INLINE -

TARGET PRICE - *£ 1000*

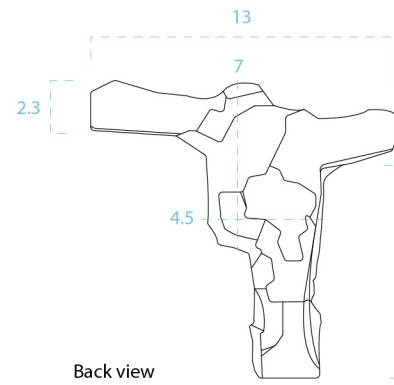
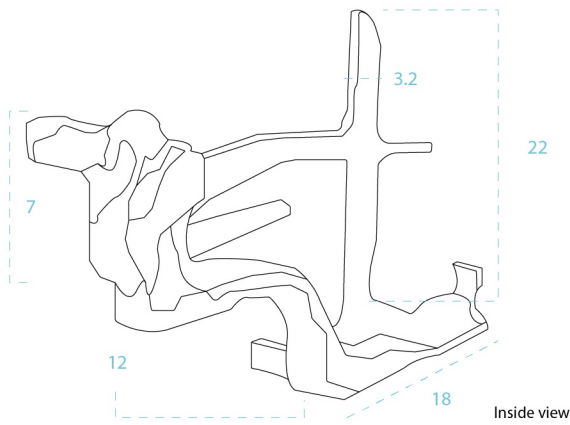
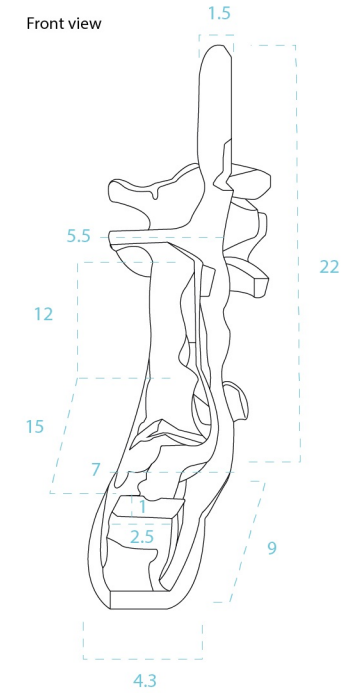
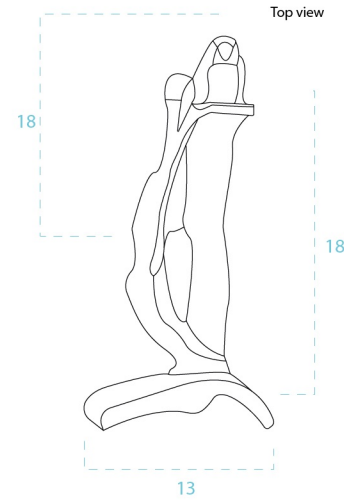
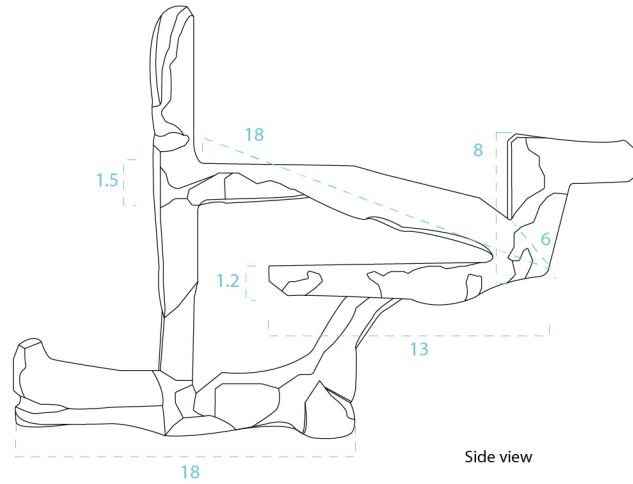

Heel structure texture
: Rock - Plaster + Coloured