

SS24

TO BE AGAIN THAT'S  
THE QUESTION

MENSWEAR

Hsuan Yu Chen

## *"To Be Again That's The Question"*

This is how the story begins.  
Have you ever tried to observe an  
object through a spike of glass?  
If too close, it blurs confused,  
dreamlike .

Try to observe the object from  
distance, and you will see that it  
becomes clear.

Just like death nothing last, nothing  
lost, it's only a veil of smoke, all you  
have to do is to stretch your hands  
through it and you will reach the  
ones you love .

Just as the modern world  
technology and informations are  
taking a huge leap forward. But what  
do we forget and lose?

When does earth  
become a field to play the  
games, politics, economy, war?

Should we slow our steps, to  
quest, to explore the nature, the  
environment.

To find out who we are, where we  
come from, as to be in the present,  
we are the link, the border of the  
past and the future, to be in between  
is the only way to truly understand.  
For the things we have done, what  
has been done will never disappear,  
for the things haven't done it blurs  
confused, dreamlike.

## *"To Be Again That's The Question"*

### *"SS24"*

The Collection is inspired by "The Book Of  
Vision"

The movie is about when the Enlightenment is  
replacing the mysticism, the nature, just as how the  
modern world is going.

"To Be Again That's The Question" the  
collection is heading towards the future where  
as everything repeats again in a brand new  
appearance, Modern Avantgarde.

The Collection is designed in the sustainable way  
since the start by using fully natural material, and  
handcrafted fabrics, every process during the craft  
is natural with out glue and chemicals, so as the  
color, it's fully natural dye.

The material for the collection is personally  
handmade transparent wool with three version  
(fully glass like transparent, double-sided semi-  
transparent, and thick double-sided transparent)  
with different variation of natural dye colors, also  
leather.

The combination of the fabrics gives the feeling  
of mystery, confused, illusion, just as how its like  
when generation change.

The silhouette represent the fall and the death  
of imaginary dynasty by the the naturally drop of  
the shape that shows the face and the back of the  
fabric



TO BE AGAIN THAT'S THE QUESTION



TO BE AGAIN THAT'S THE QUESTION

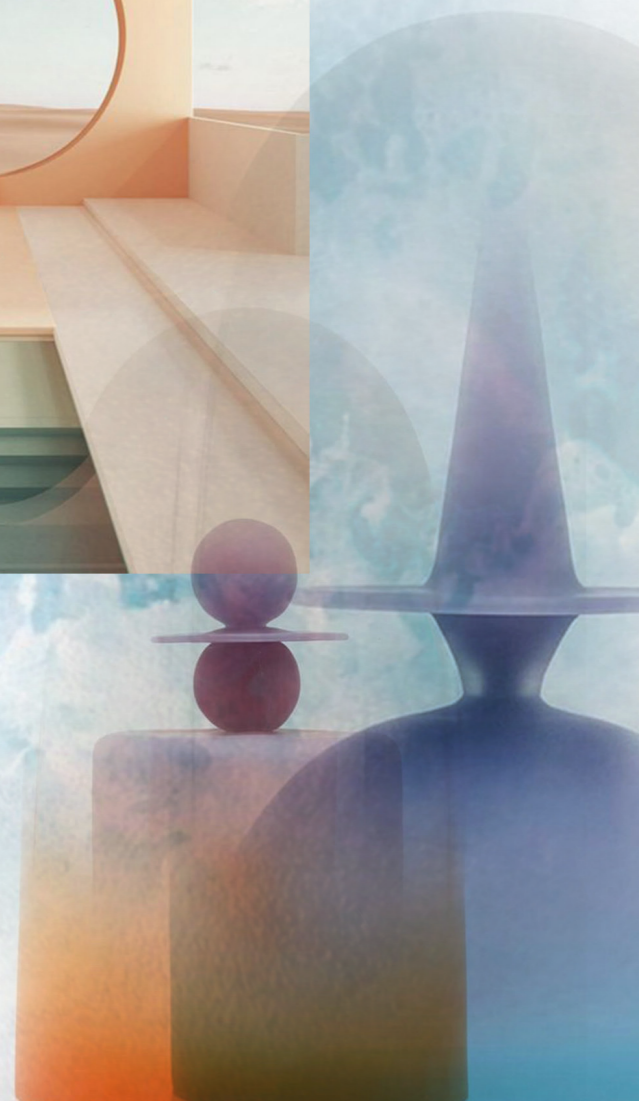

# Fabric Crafting & Manipulation Process

HAND MADE SEMI TRANSPARENT DOUBLE WOOL  
FULLY NATURAL CONSTRUCT & DYE

(Fabric Crafting)

## 1. Dying



Dye the base fabric (Silk) with natural dy and secure the color with modarnt.

## 2. Deconstruct

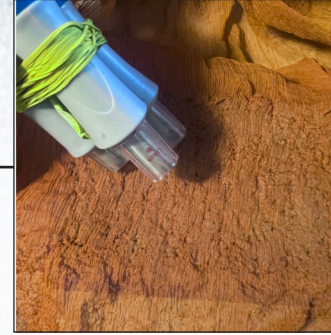

Break the weaving of the fabric to creat texture by dry felting.

## 3. Wet Felt

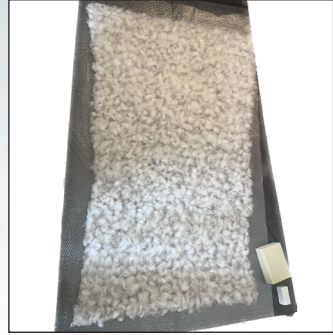

Wet felt wool fiber (amount of wool depends of how thick and transperancy the final result is) with two piece of base fabric (top&bottom) .

## 4. PH12 liquid dip

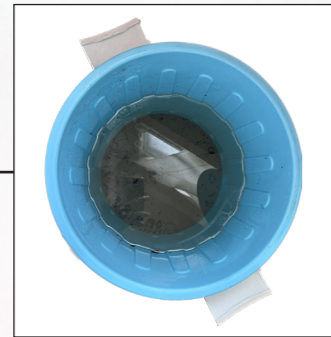

Dip the fabric into high PH liquid (wood ash water) to make the fabric shrink and creates texture.

## 5. Iron&Pull



Iron and pull the fabric to make the width wider.



DIFFERENT COLOR VARIATION



DIFFERENT COLOR VARIATION



TO BE AGAIN THAT'S THE QUESTION

# Fabric Crafting & Manipulation Process

## TRANSPARENT WOOL FULLY NATURAL CONSTRUCT & DYE

(Manipulation)

### 1. Dying



Dye the base fabric (Silk) with natural dy and secure the color with modarnt.

### 3. Wet Felt



Wet felt very small quantity of wool fiber with the base fabric.

### 5. Iron&Pull



Iron and pull the fabric to make the width wider.

MA1

### 2. Deconstruct

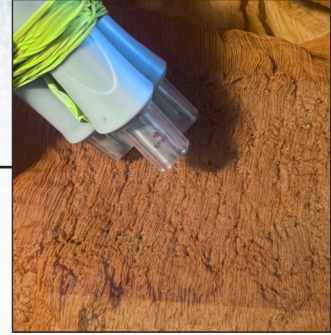

Break the weaving of the fabric to creat texture by dry felting.

### 4. PH12 liquid dip

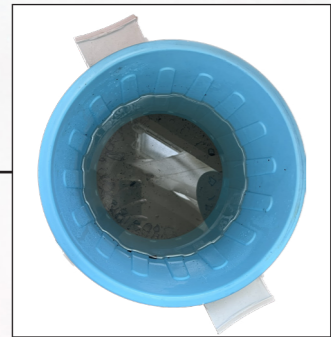

Dip the fabric into high PH liquid (wood ash water) to make the fabric shrink and creates texture.



DIFFERENT COLOR VARIATION



DIFFERENT COLOR VARIATION



TO BE AGAIN THAT'S THE QUESTION

# Ombre Dying

## Leather Indigo FULLY NATURAL Ingridient & DYE

OB1

### 1. Wet The Leather

Wet the leather completely with warm water

### 2. Paint

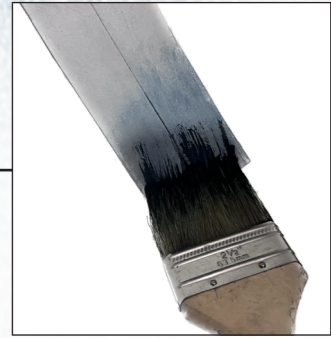

Paint the indigo mud on leather (amount of paint depends on how dark the color is)

### 3. Sponge



Use sponge to push the mud (let the color goes in the leather)

### 4. Indigo Pot Dye



Dye leather into Indigo Pot to secure the color and even the guide line.

### 5. Wash

Wash the extra pigment by warm water.



## Fabric FULLY NATURAL Ingridient & DYE

OB2

### 1. Wet The Fabric

Wet the fabric completely with warm water

### 2. Base Color

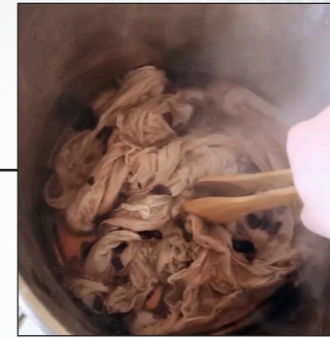

Dye the garment completely in dye bath (time depends on how dark the base color is)

### 3. Pull



Pulling the garment up and down, by the help of the gravity the guideline of color blends.

### 4. Secure

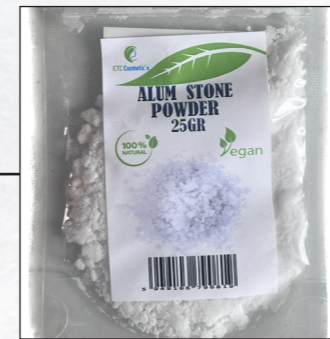

Secure the color of garment in mordant (depends on witch fabric)

### 5. Wash

Wash the extra pigment by warm water.



## Rubber Indigo FULLY NATURAL Ingridient & DYE

OB3

### 1. Sand



Sand the surface with sand papper to create spaces for pigment.

### 2. Paint



Paint the indigo mud on rubber (amount of paint depends on how dark the color is)

### 3. Sponge



Use sponge to push the mud (let the color goes in the rubber)

### 4. Indigo Pot Dye

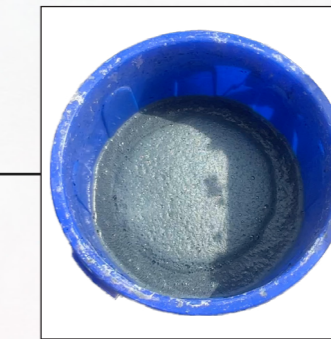

Dye rubber into Indigo Pot to secure the color and even the guide line.

### 5. Wash

Wash the extra pigment by warm water.



# Fabric Chart

runway collection



F01

Semi Transparent wool  
Silk 18% Wool 72%



C01

C02



F02

Semi Transparent wool  
Silk 18% Wool 72%

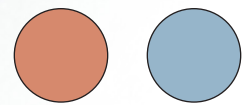

C10

C02



F03

Semi Transparent wool  
Silk 18% Wool 72%

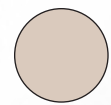

C07

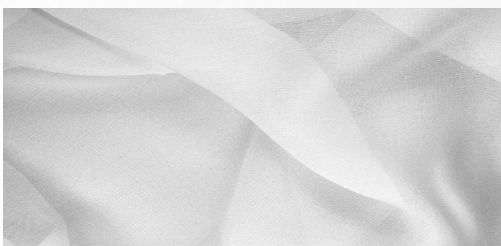

F04

Silk Chiffon  
100% Silk



C01

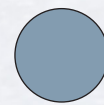

C03

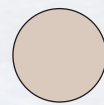

C07

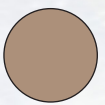

C09

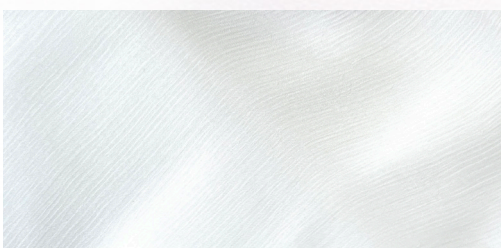

F05

Mulberry Silk  
100% Silk

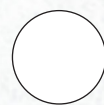
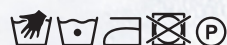

C01

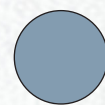

C03

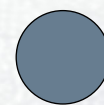

C04



C10



C11

# Fabric Chart

*runway collection*



F06

Vegetabile Tanned Calf Leather  
100% Calf Leather

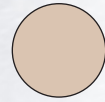

C08



F07

Calf Leather  
100% Calf Leather

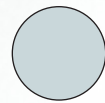

C12

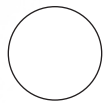

C01



F08

Calf Leather  
100% Calf Leather

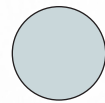
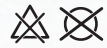

C12



C05



# Hardware Chart



H01

Matte pearl button

28 L

18 mm

11/16 Inch

100% Pearl

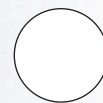

C01

# Color Chart



# Ot1 Production Chart



## Outfit Description (outside to inside)

**1<sup>st</sup> garment**  
Semi transparent wool jacket with one piece collar and raw cut pocket

+

**2<sup>nd</sup> garment**  
Raw cut leather vest with draped collar and indigo ombre

+

**3<sup>rd</sup> garment**  
Indigo transparent wool cardigan

+

**4<sup>th</sup> garment**  
Semi transparent wool draw string short

## Fabric & Hardware

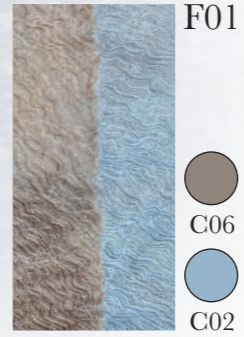

F01

C06

C02

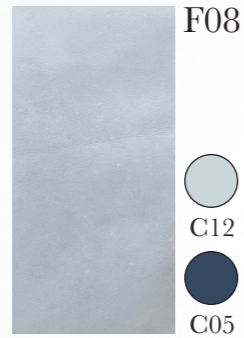

F08

C12

C05

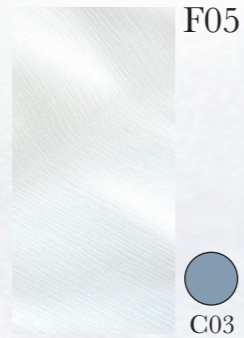

F05

C03

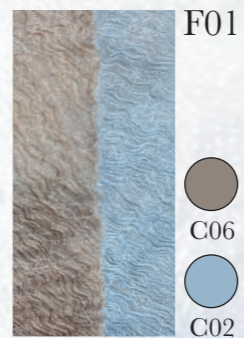

F01

C06

C02

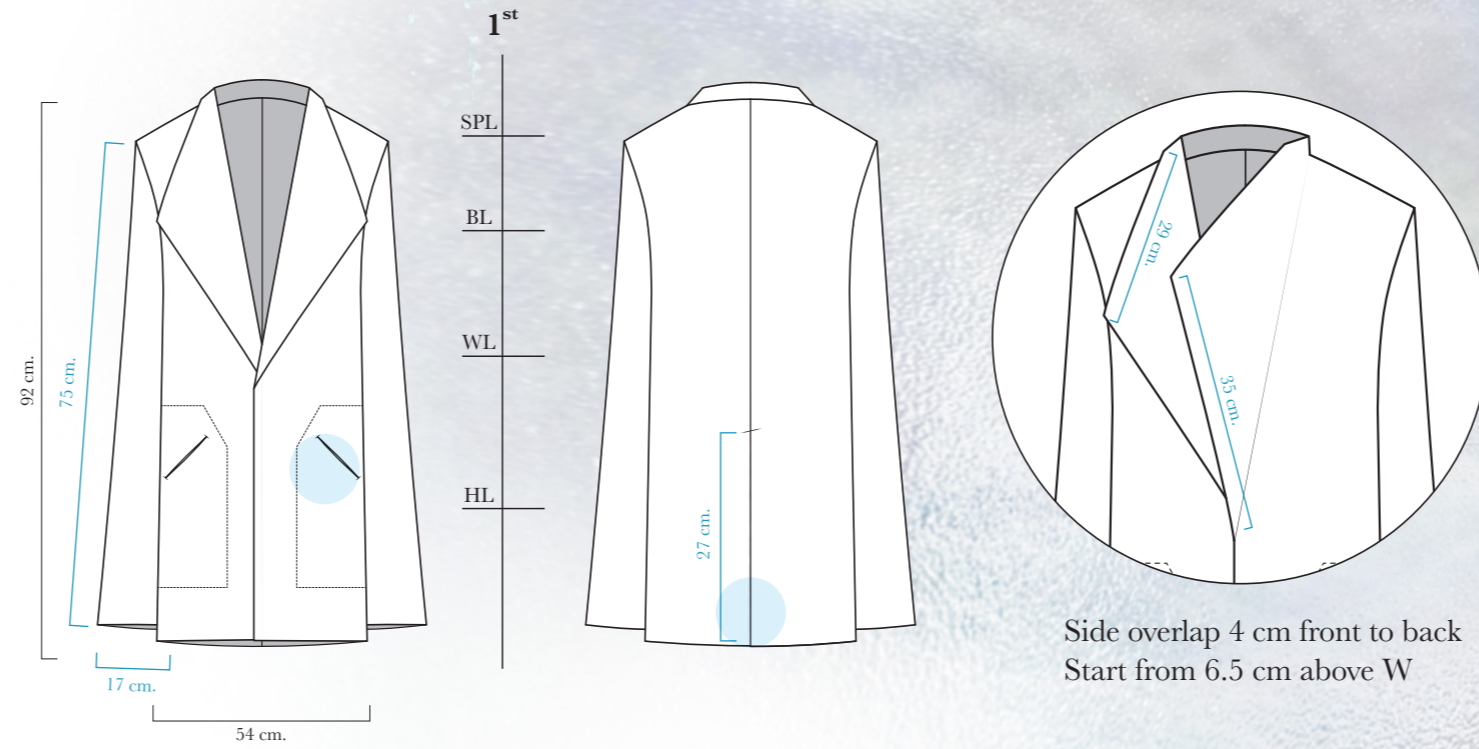

Side overlap 4 cm front to back  
Start from 6.5 cm above W

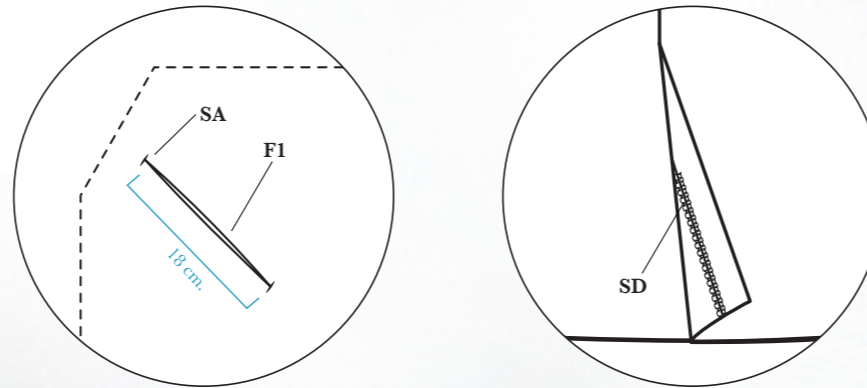

Raw cut pocket 18cm

4cm folded in back vent

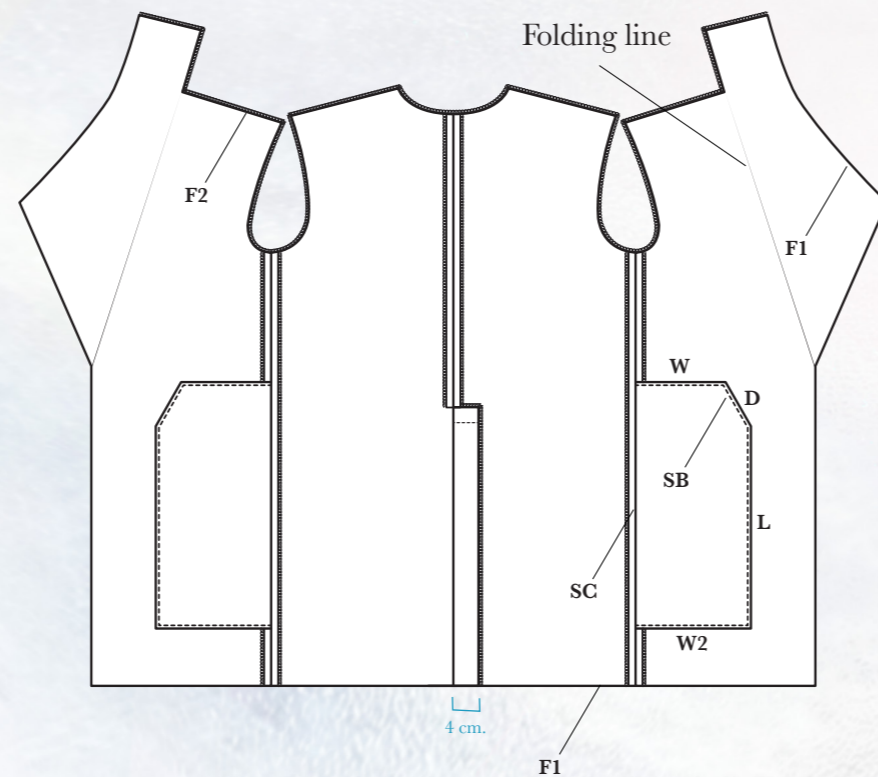

## Stitching&Distance

- SA.** Hand stitch 5 mm on both end of raw cut pocket
- SB.** Top Stitch pocket  
W - 160mm  
D - 95mm  
L - 200mm  
W2 - 210mm
- SC.** Side of pocket stitched with side of the body 10mm
- SD.** Hand invisible stitch 5mm from the edge

## Finishing

- F1.** Raw cut on the edge
- F2.** 3 line overlock 0.5 cm on the edge with matching color

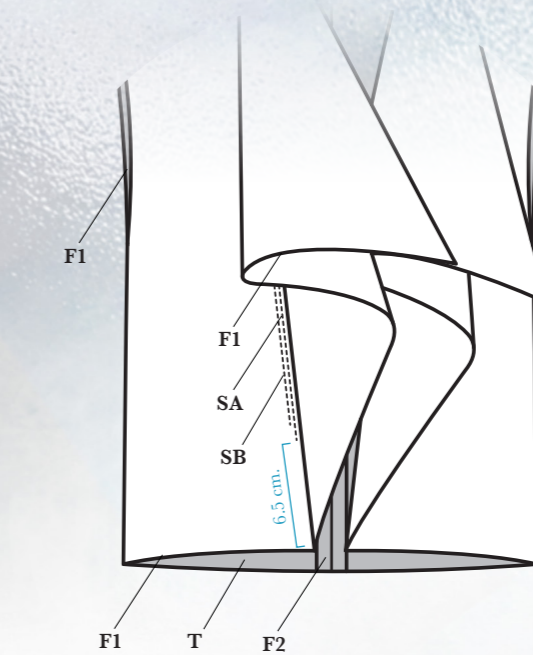
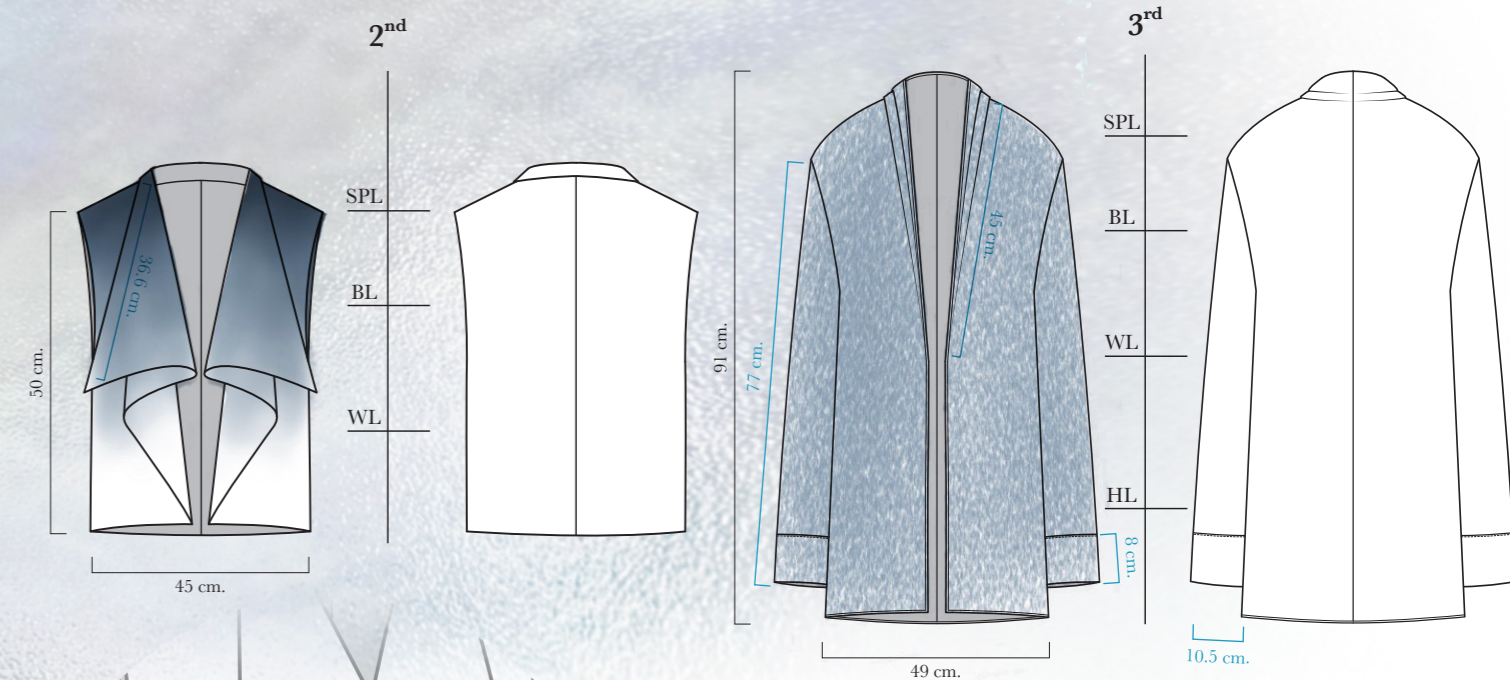

Collar stitch back to back with the body.  
Glue the first 6.5cm without stitches.

## Stitching&Distance

- SA.** Stitched with matching color 3mm from the side
- SB.** Stitched with matchin color 7mm from the side

## Finishing&Trimming

- F1.** Raw cut finish on the edge
- F2.** 10mm seam allowance both side glued flat with body
- T1.** Trim with **clear cream** for leather finish

## Manipulation & Dying

- OB1.** Color transition C05 - C12 start from the top

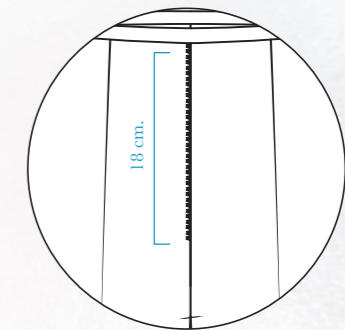
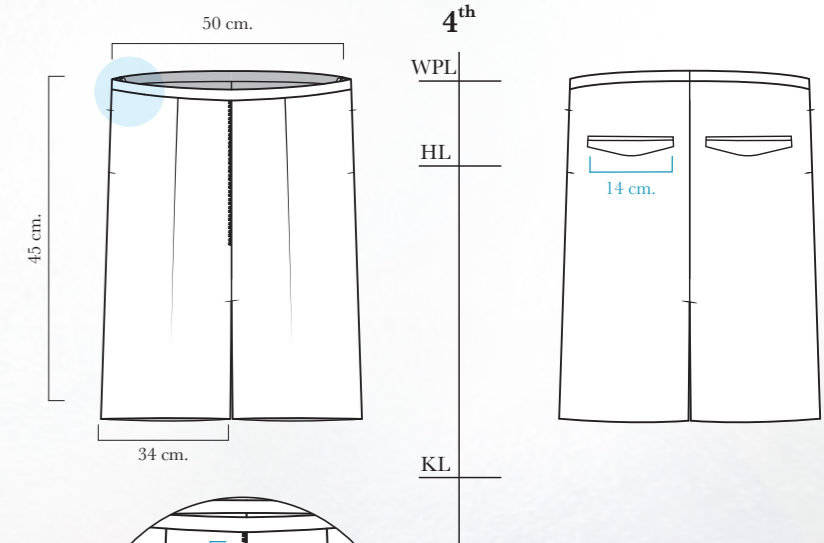

Insert selvedge of wasted fabric in ctf

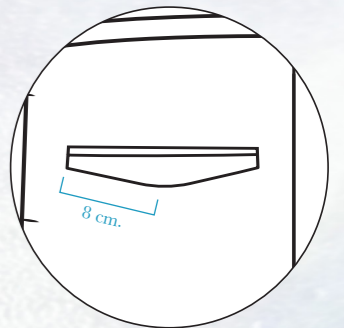

Welt. length - 150mm  
width - 5mm

Flap. length - 150mm  
width - 35mm

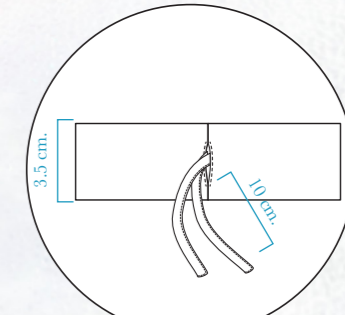

1.5 cm opening  
Stripe 1 cm  
In the inner part of belt

# Ot2 ProductionChart

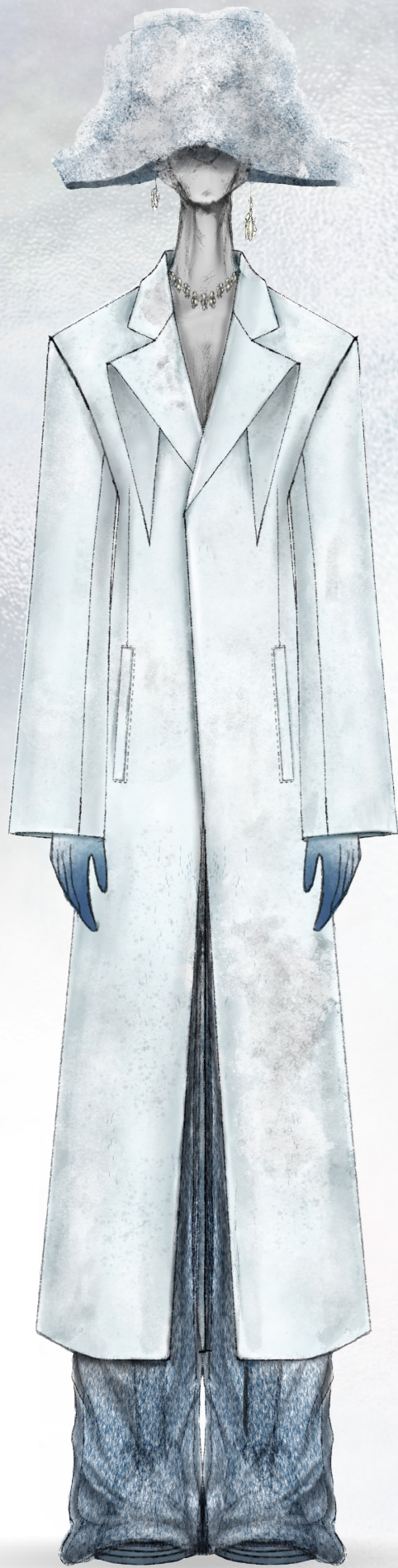

## Outfit Description (outside to inside)

**1<sup>st</sup> garment**  
Raw cut leather Coat  
with draped collar  
and 3 high vent

**2<sup>nd</sup> garment**  
Flared trouser with  
transparent wool  
manipulation and  
indigo ombre

**3<sup>rd</sup> garment**  
Flared trouser with  
transparent wool  
manipulation and  
indigo ombre

## Fabric & Hardware

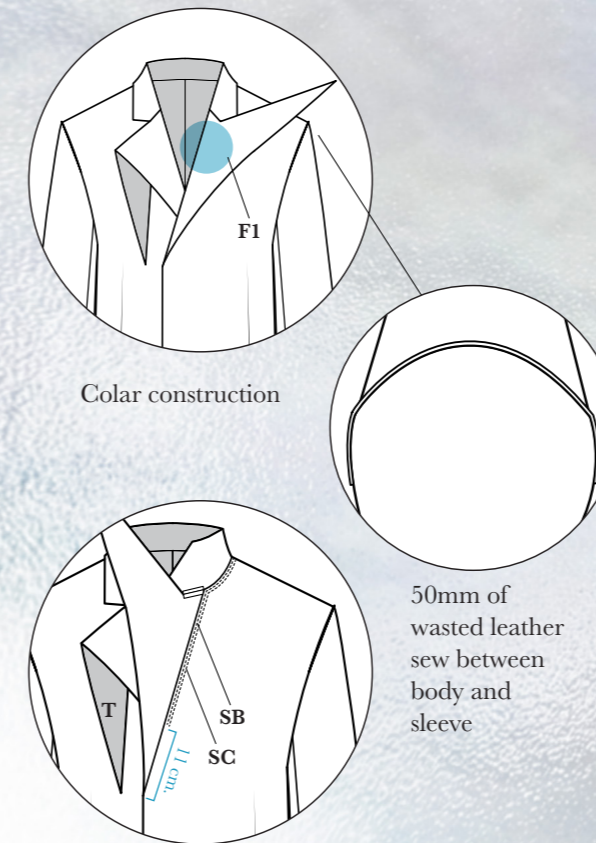
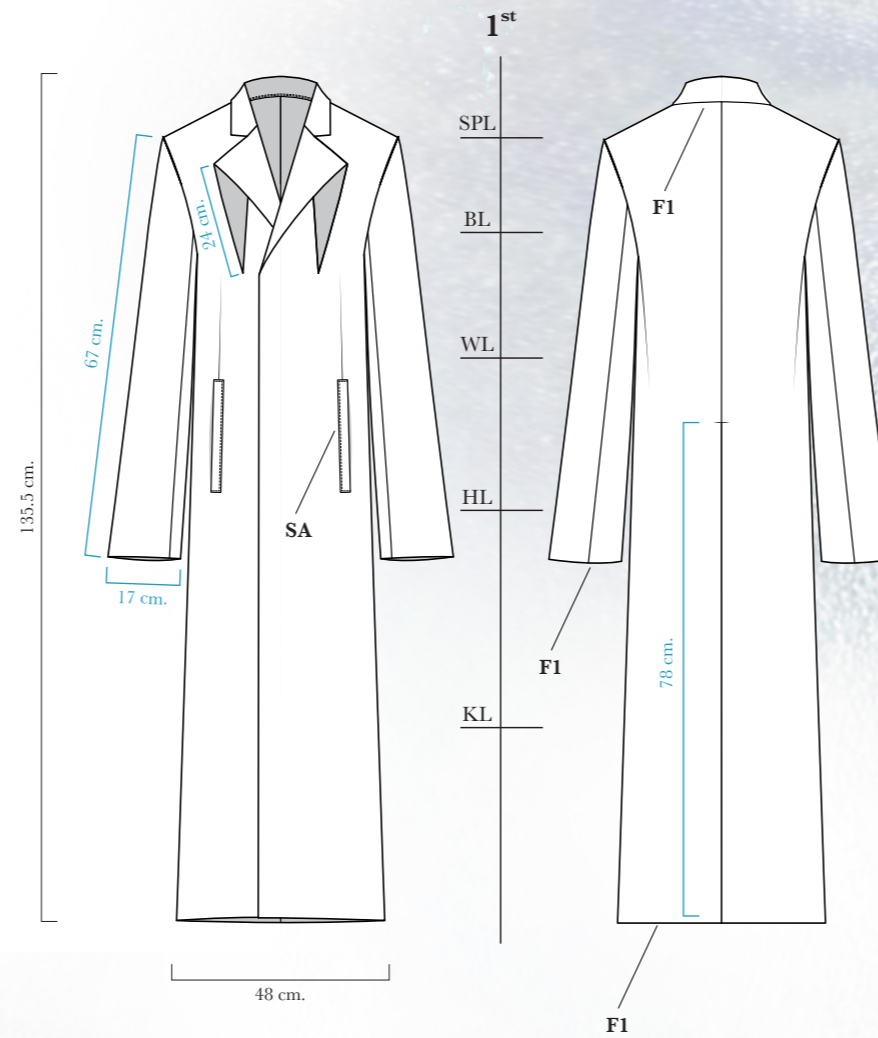
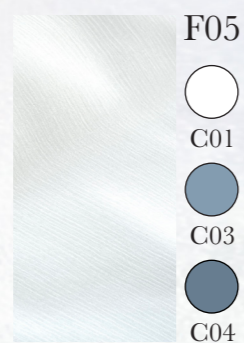
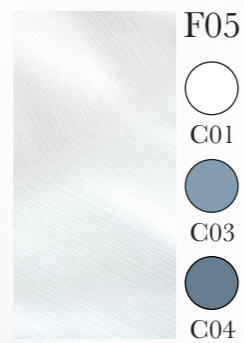

Color stitch back to back with the body.  
Glue the first 11cm without stiches.

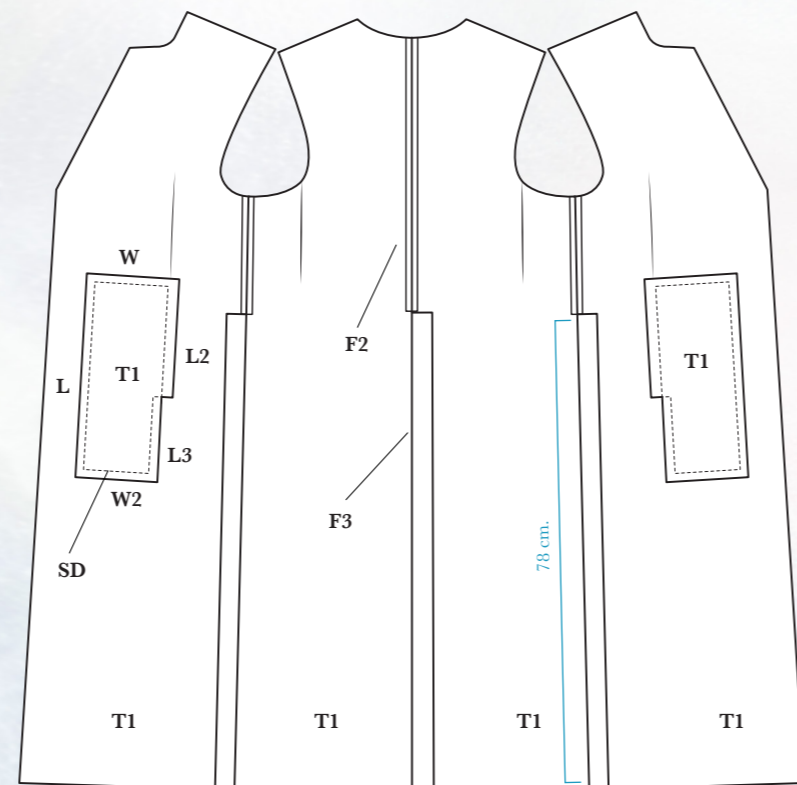

## Stiching&Distance

- SA.** Welt pocket stitch matching color  
Width - 20mm/length - 190mm
- SB.** Stitch matching color  
3mm from the side
- SC.** Stitch matching color  
7mm from the side
- SD.** Welt pocket stitch  
W - 115mm  
W2 - 120mm  
L - 285mm  
L2 - 195mm  
L3 - 85mm

## Finishing&Trimming

- F1.** Raw cut finish on the edge
- F2.** 10mm seam allowance both side glued flat with body
- F3.** 40mm seam allowance glued flat with body

**T1.** Trim with **clear cream for leather finish**

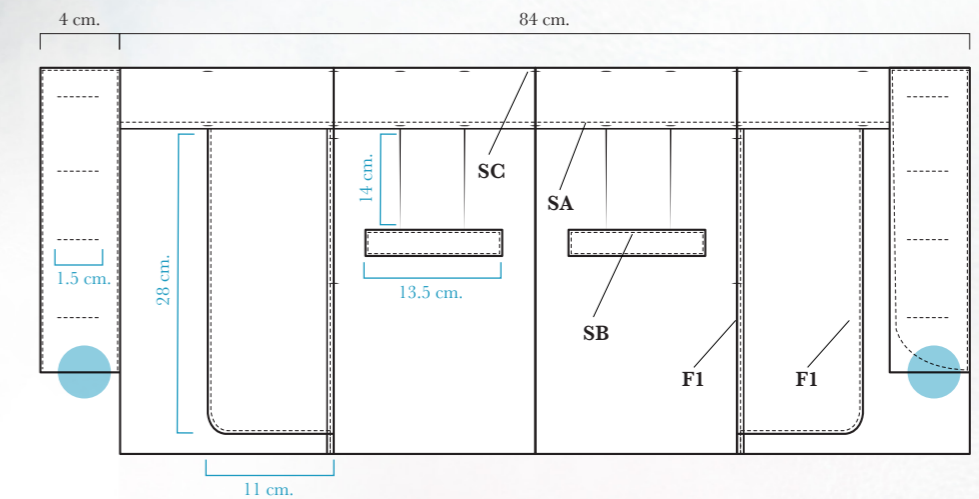
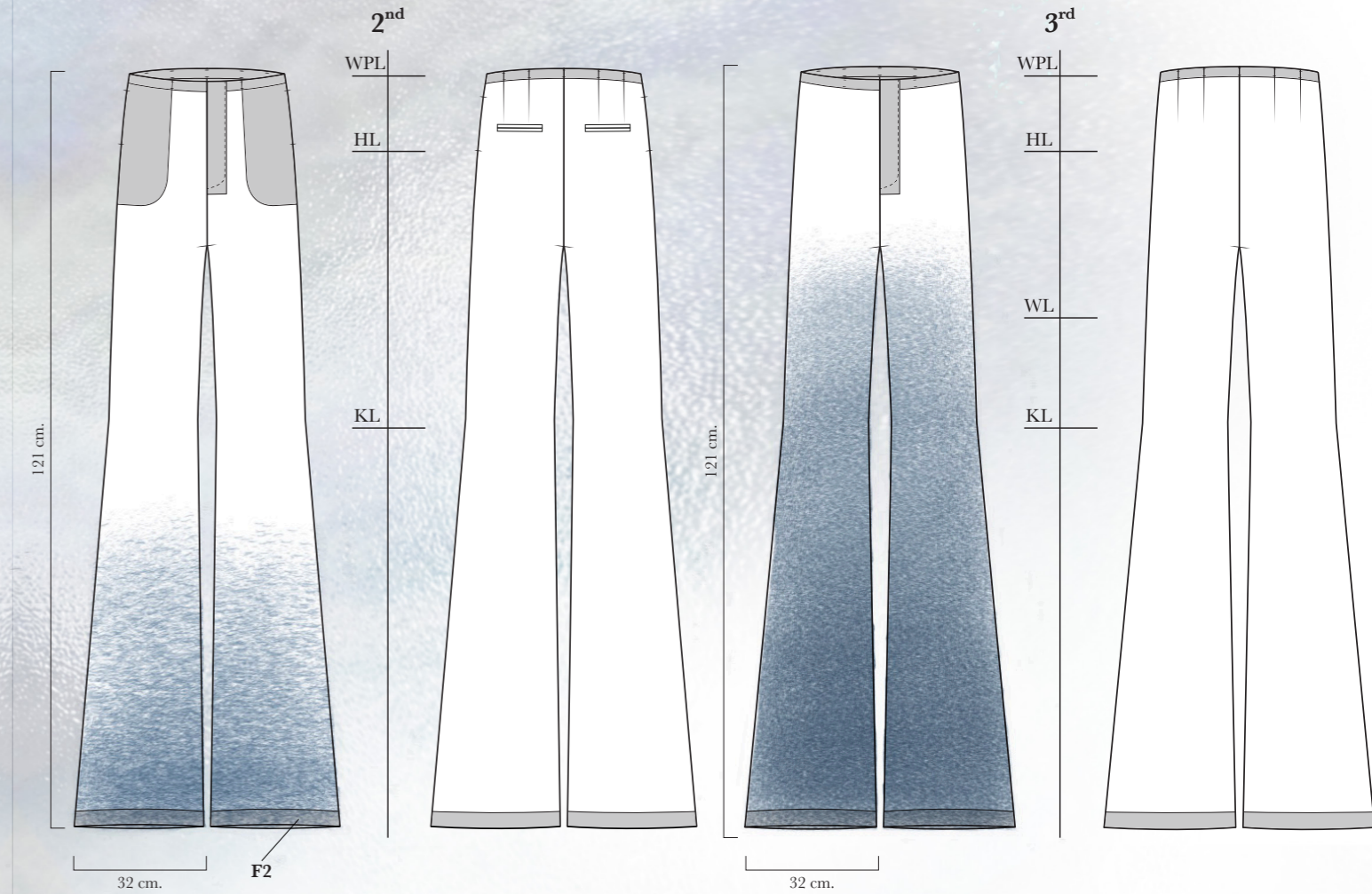

## Stiching&Distance

- SA.** Stitched belt turned 10mm
- SB.** Stitch matchin color  
5mm
- SC.** Stitch matchin color  
3mm from the side

## Finishing

- F1.** French seam finishing
- F2.** 40mm hem hand stitched finishing
- F3.** Stitch matchin color  
7mm from the side

## Manipulation & Dying

- OB2.** Color transition C04 - C03 - C01  
start from bottom
- MA1.** Manipulation on OB2, ends 10cm  
below KL

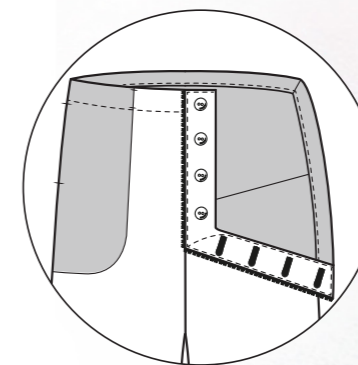

One piece selvedge  
cut fly

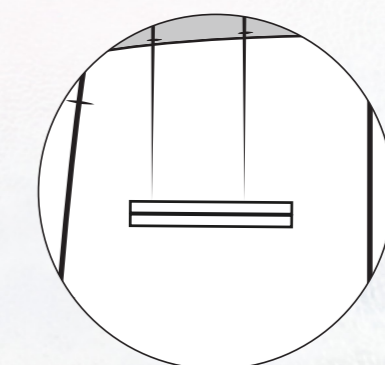

Welt. length - 10mm  
width - 135mm

# Ot3 ProductionChart



## Outfit Description (outside to inside)

### 1<sup>st</sup> garment

Long shirt with draped collar, semi transparent wool manipulation and brown ombre

+

### 2<sup>nd</sup> garment

Long shirt with draped collar, semi transparent wool manipulation and brown ombre

+

### 3<sup>rd</sup> garment

Raw cut leather vest with onepiece draped collar

+

### 4<sup>th</sup> garment

Semi transparent wool draw string short

## Fabric & Hardware

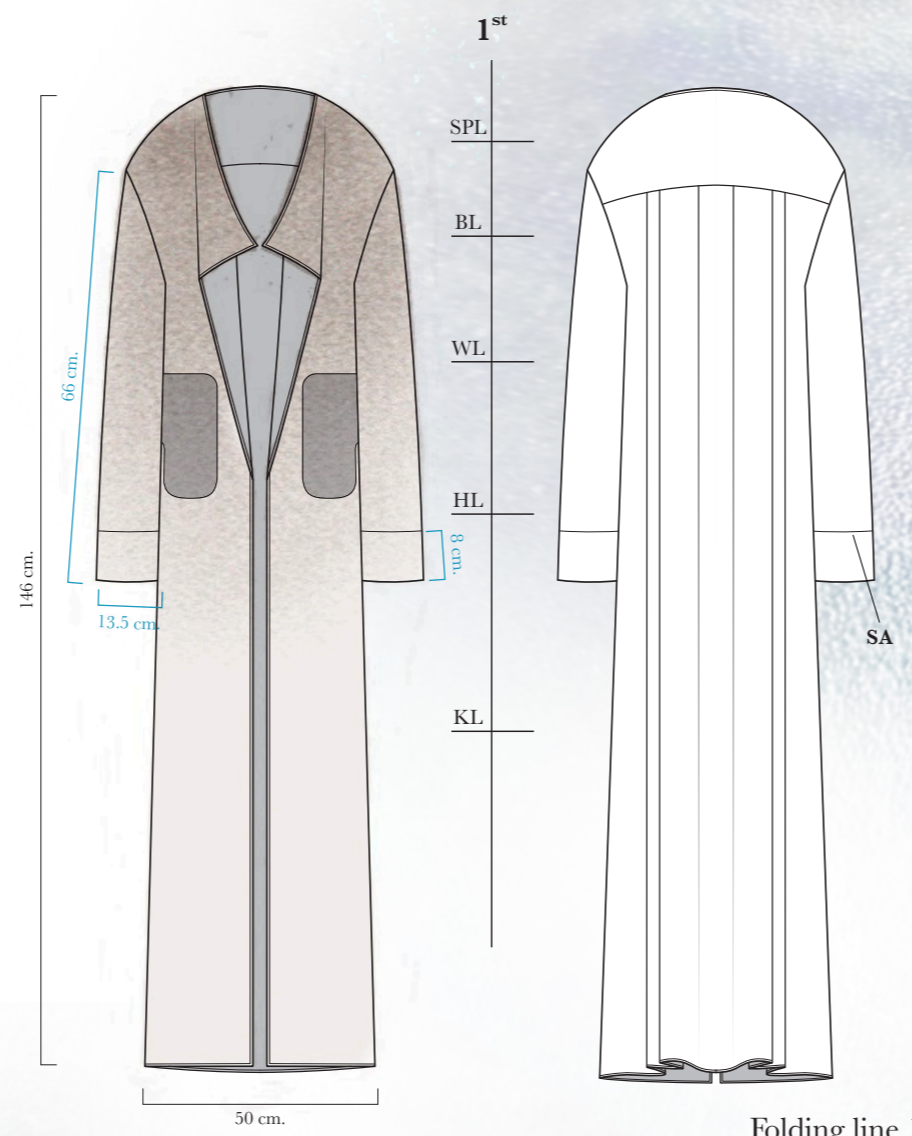
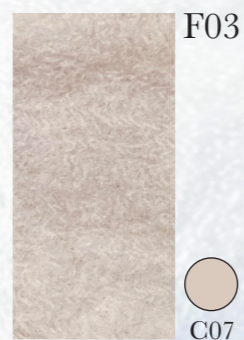
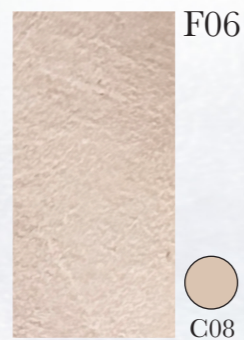
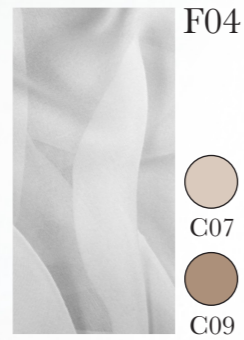

## Stiching&Distance

- SA. Top stitch 1mm on cuff
- SB. French seam pocket stitch  
W - 135mm  
W2 - 110mm  
L - 230mm  
L2 - 175mm

## Finishing

- F1. Hand sew roll hem finish 5mm
- F2. French seam

## Manipulation & Dying

- OB2. Color transition C09 - C07 start from the top
- MA1. Manipulation on OB2, ends 10cm below HL

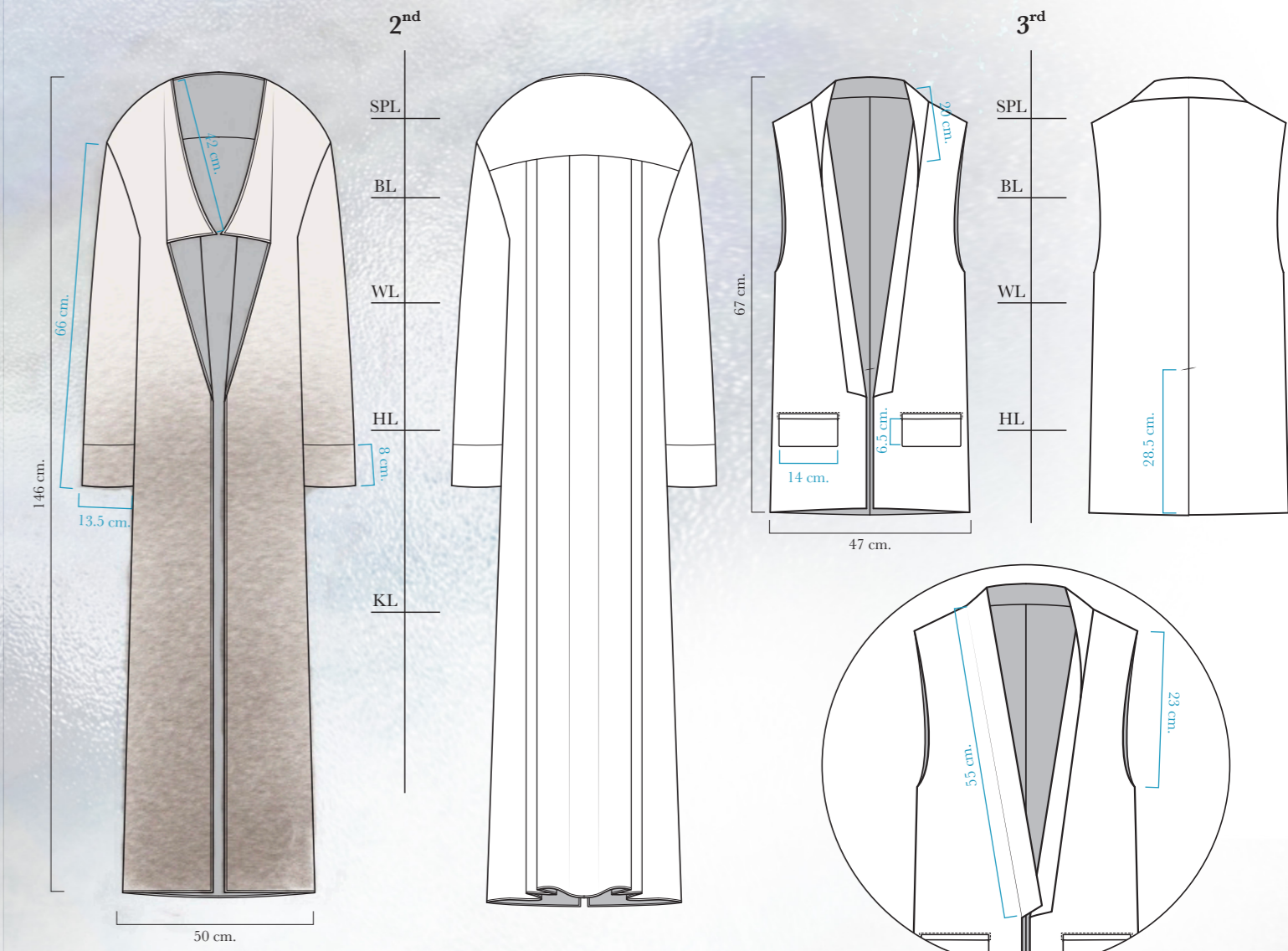
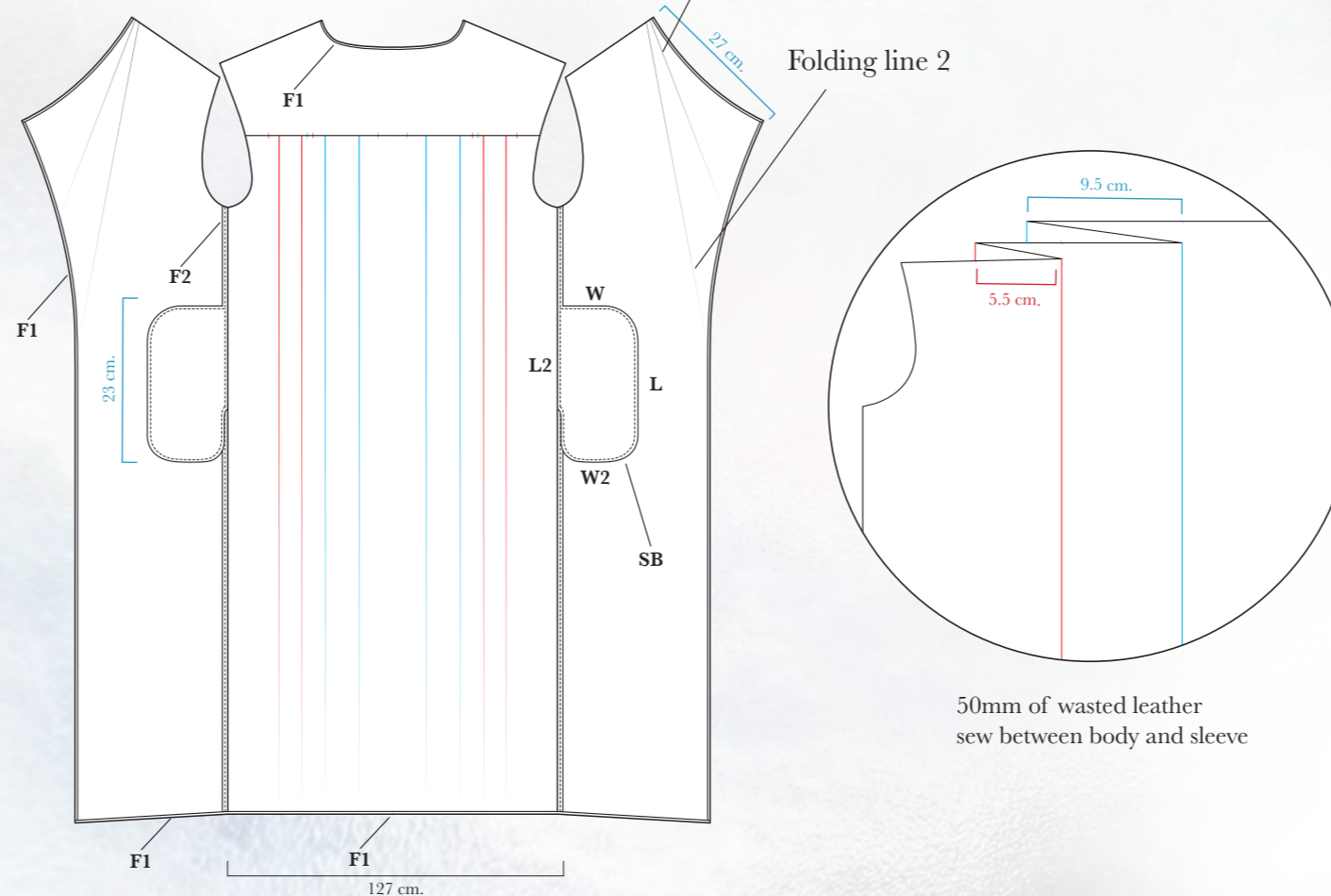

## Manipulation & Dying

- OB2. Color transition C09 - C07 start from bottom
- MA1. Manipulation on OB2, end 10cm above HL.

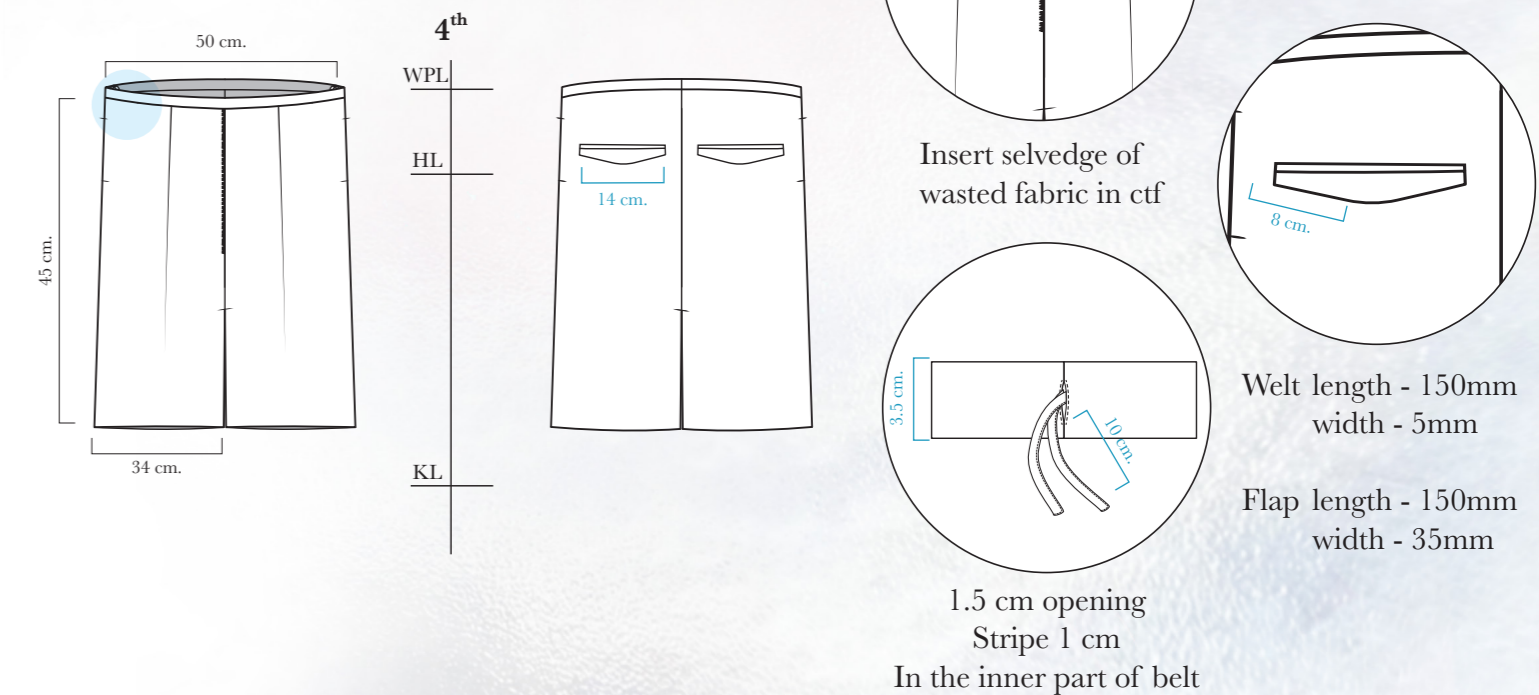

# Ot4 ProductionChart



## Outfit Description (outside to inside)

**1<sup>st</sup> garment**  
Semi transparent wool jacket with one piece draped collar and raw cut pocket

**2<sup>nd</sup> garment**  
Indigo transparent wool tank top

**3<sup>rd</sup> garment**  
Flared trouser with transparent wool manipulation and indigo ombre

**4<sup>th</sup> garment**  
Flared trouser with transparent wool manipulation and orange ombre

## Fabric & Hardware

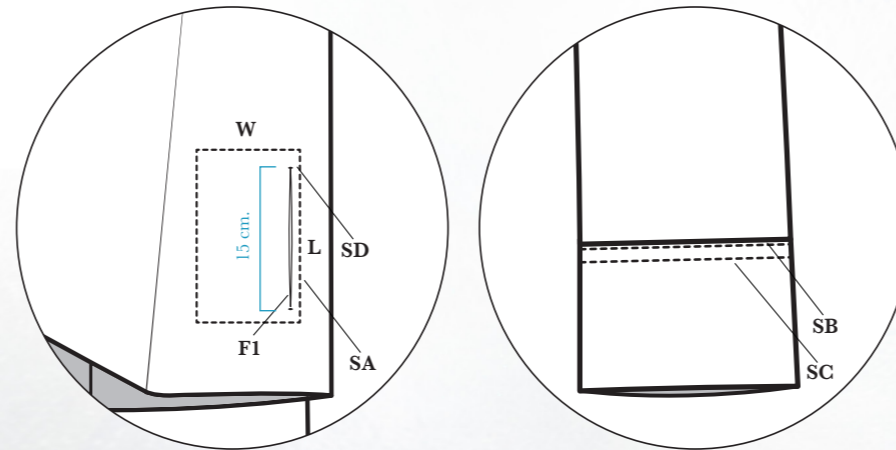
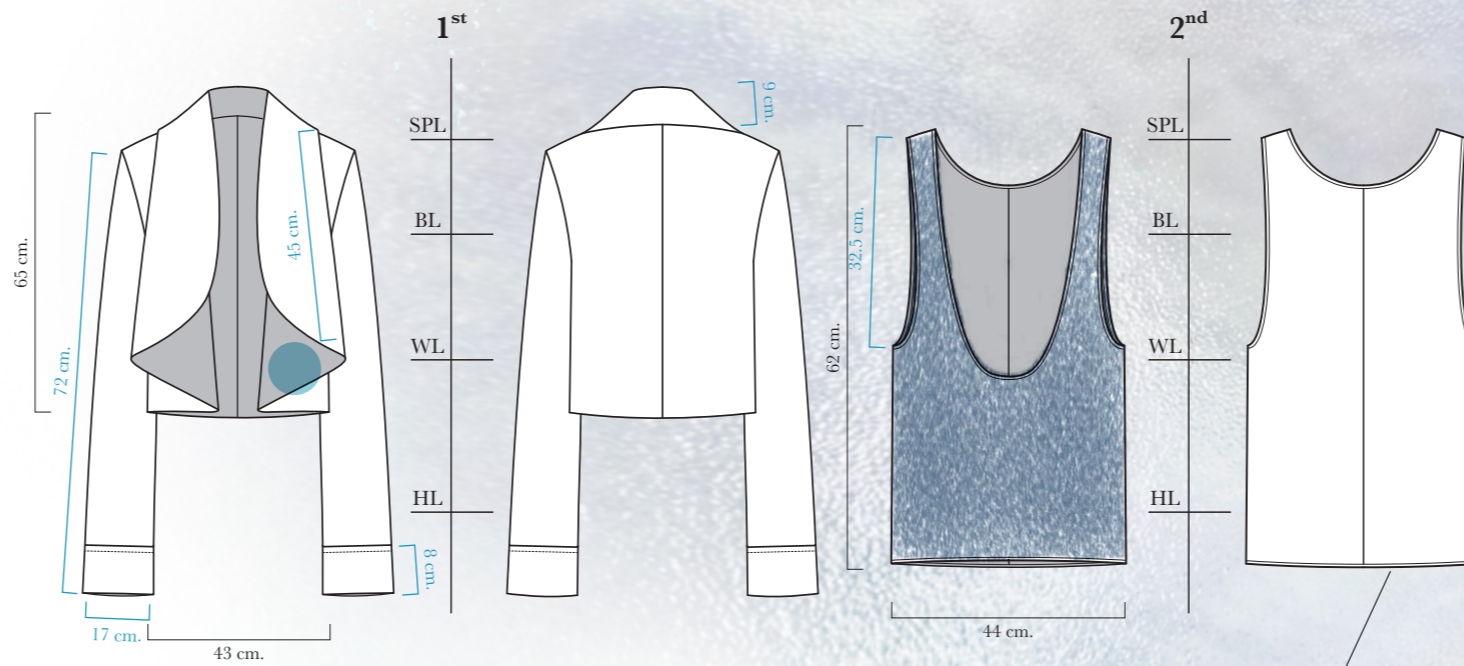
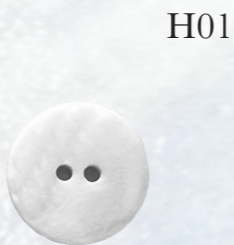
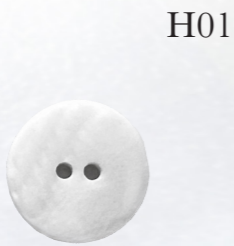
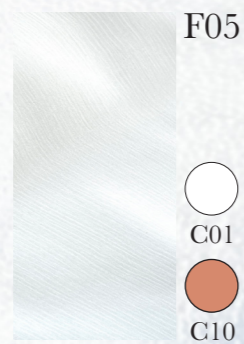
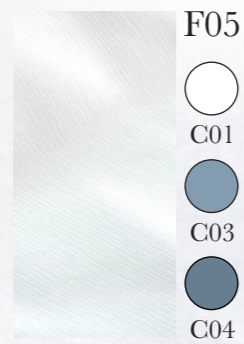
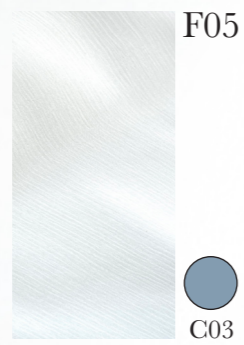
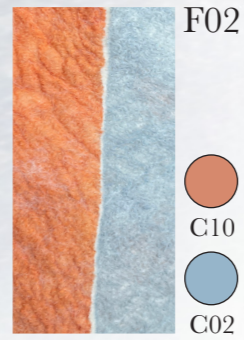

Raw cut pocket 15cm

Cuff top stitching

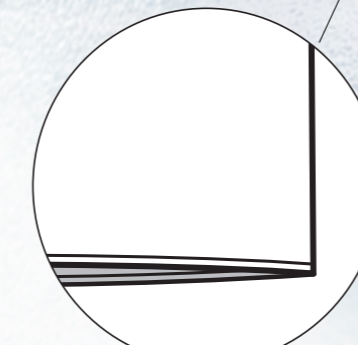
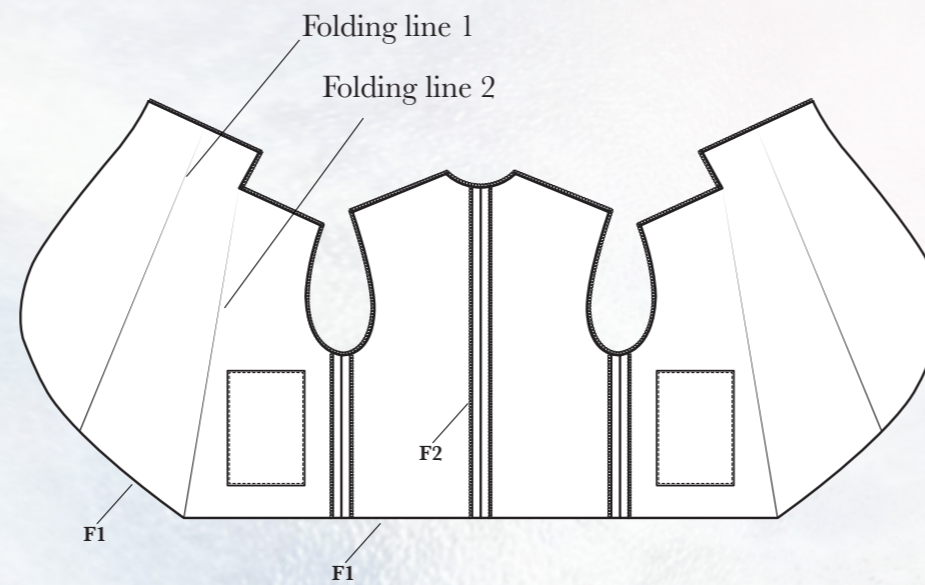

Hand sew roll hem finish 5mm

## Stiching&Distance

- SA.** Pocket top stitch width - 150mm length - 255mm
- SB.** Stitch matchin color 3mm from the side
- SC.** Stitch matchin color 10mm from the side
- SD.** Hand stitch 5 mm on both end of raw cut pocket

## Finishing&Trimming

- F1.** Raw cut on the edge
- F2.** 3 line overlock 0.5 cm on the edge with matching color

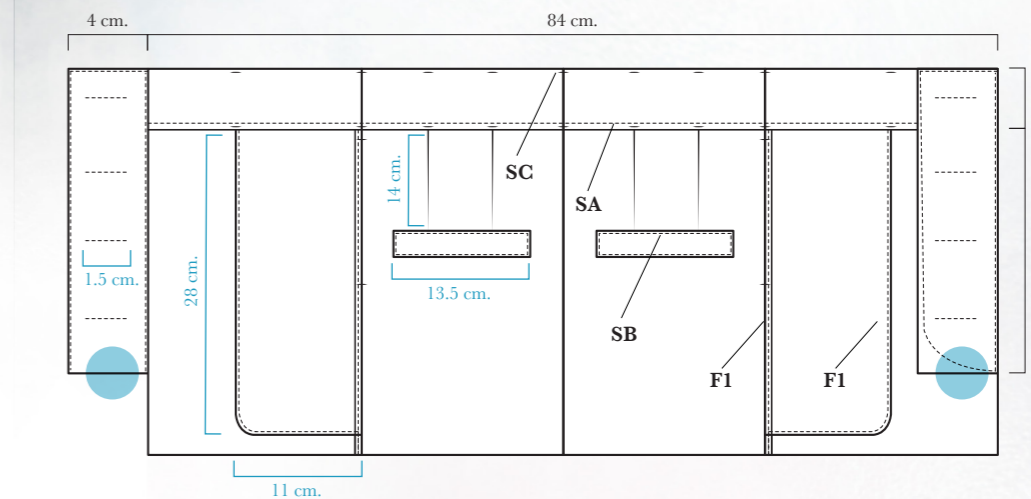
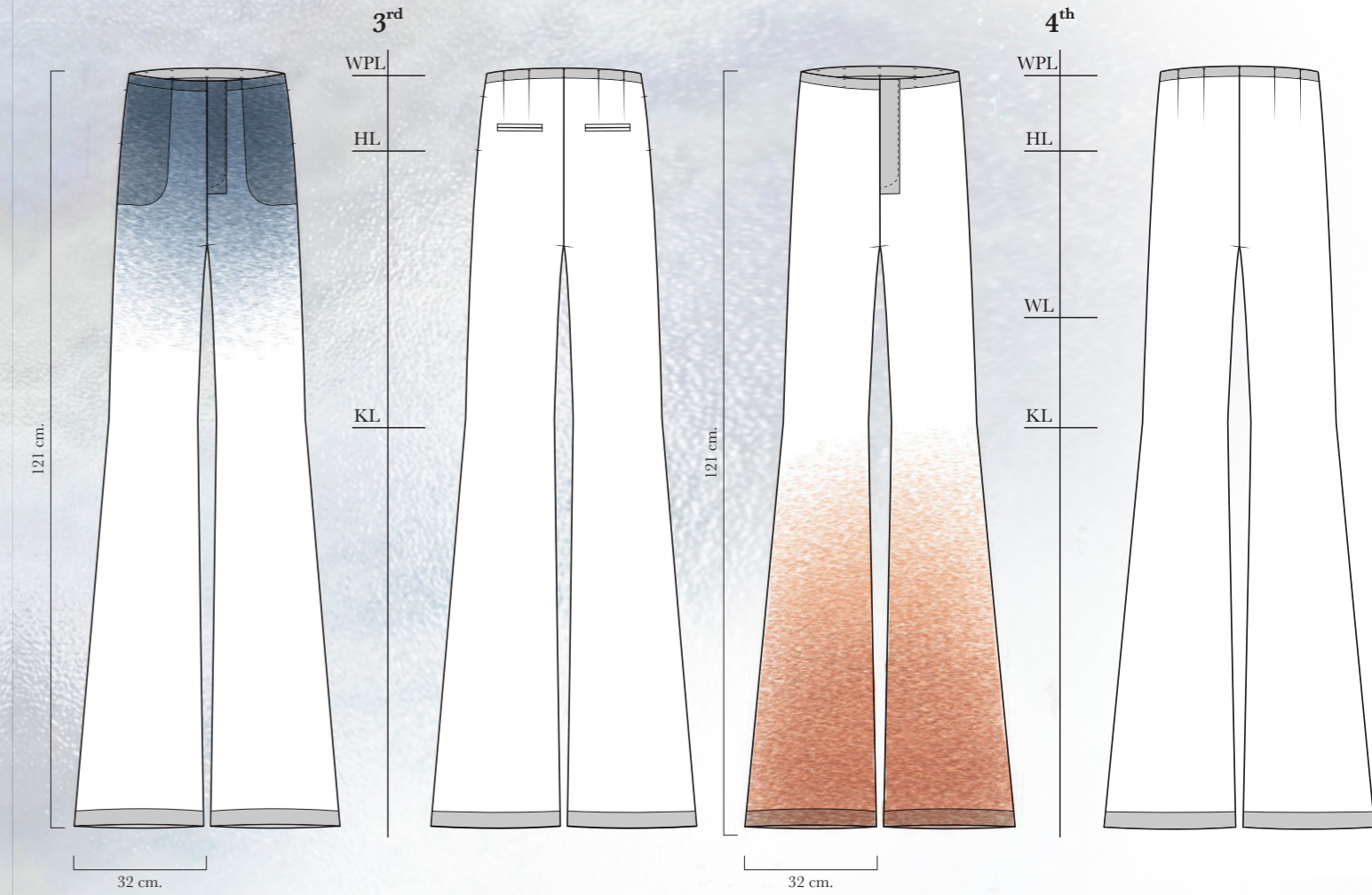

## Stiching&Distance

- SA.** Stitched belt turned 10mm
- SB.** Stitch matchin color 5mm
- SC.** Stitch matchin color 3mm from the side

## Finishing

- F1.** French seam finishing
- F2.** 40mm hem hand stitched finishing
- F3.** Stitch matchin color 7mm from the side

## Manipulation & Dying

- OB2.** Color transition C04 - C03 - C01 start from the top
- MA1.** Manipulation on OB2, ends 10cm above KL

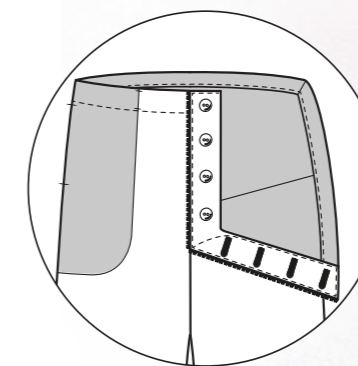

One piece selvedge cut fly

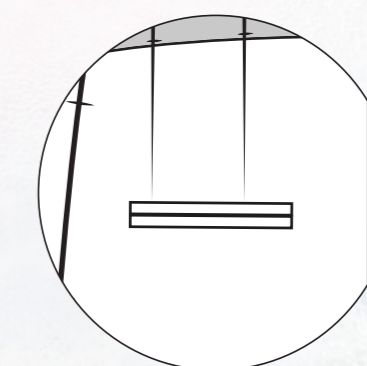

Welt. length - 10mm width - 135mm

# Ot5 ProductionChart

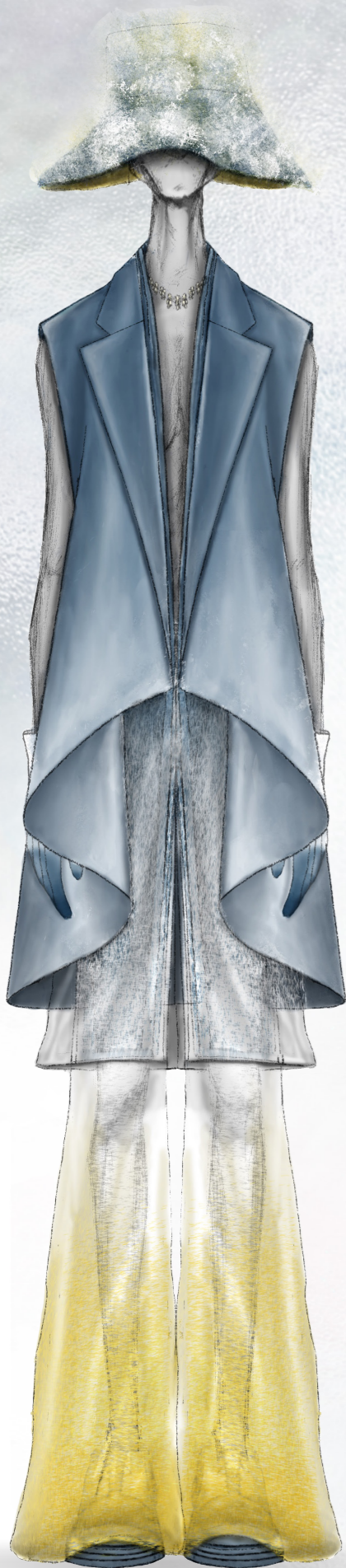

## Outfit Description (outside to inside)

**1<sup>st</sup> garment**  
Raw cut leather vest jacket with draped collar and indigo ombre

**2<sup>nd</sup> garment**  
Long cardigan shirt, semi transparent wool manipulation and indigo ombre

**3<sup>rd</sup> garment**  
Short trouser with transparent wool manipulation and yellow ombre

**4<sup>th</sup> garment**  
Flared trouser with transparent wool manipulation and yellow ombre

## Fabric & Hardware

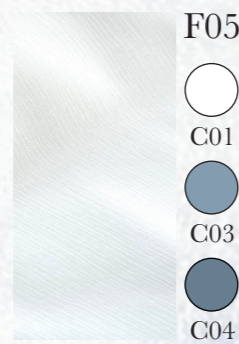
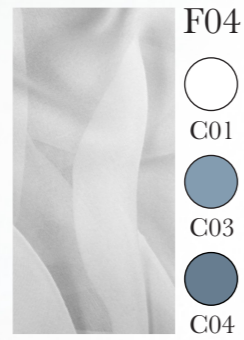

TO BE AGAIN THAT'S THE QUESTION

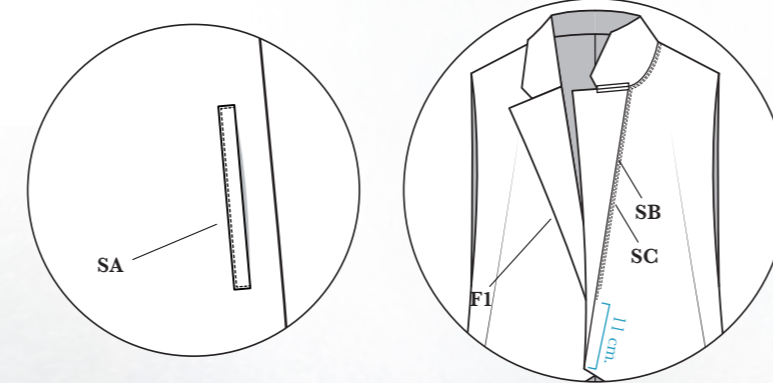
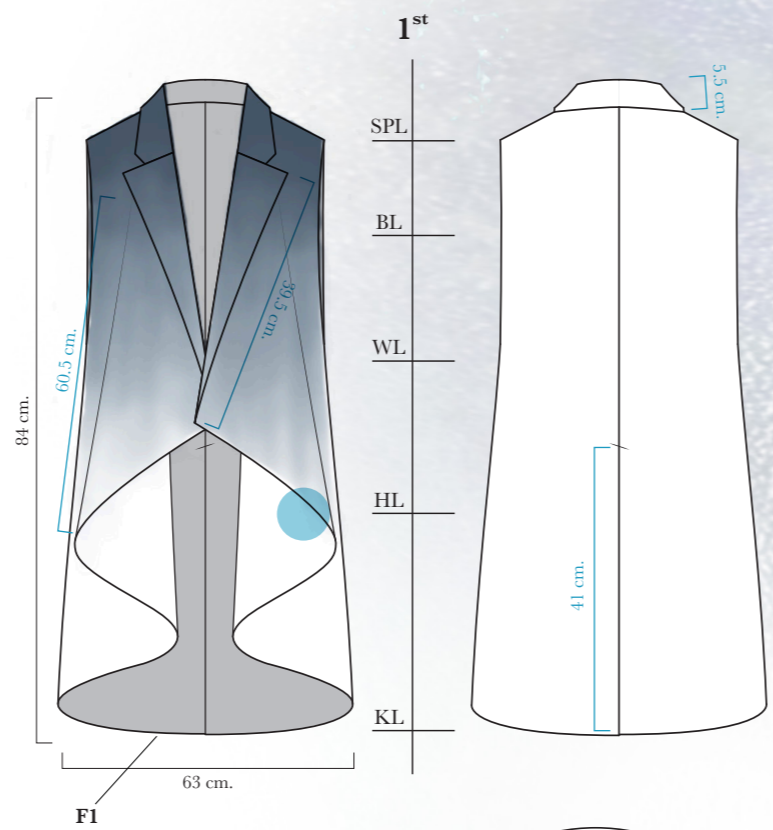

SA Single welt pocket  
SB SC Colar stitch back to back with the body. Glue the first 100mm without stiches.

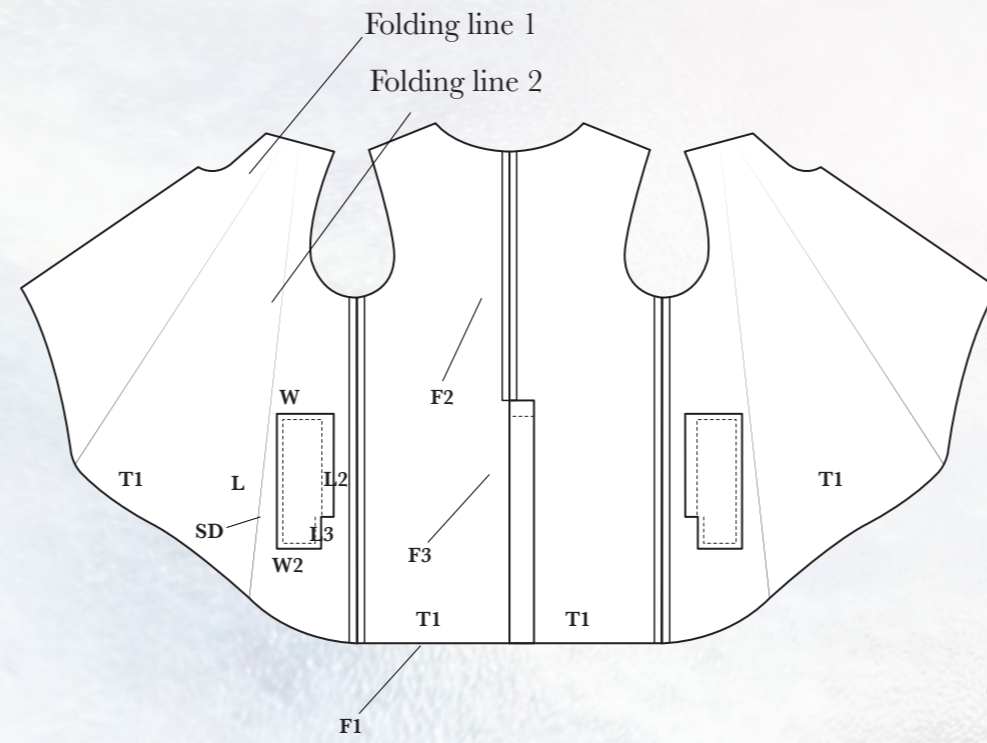

## Stitching&Distance

- SA.** Welt pocket stitch matching color  
Width - 20mm/lengh - 175mm
- SB.** Stitich matchin color  
3mm from the side
- SC.** Stitich matchin color  
7mm from the side
- SD.** French seam pocket stitch  
W - 115mm  
W2 - 120mm  
L - 285mm  
L2 - 195mm  
L3 - 85mm

## Finishing&Trimming

- F1.** Raw cut finish on the edge
- F2.** 10mm seam allowance both side glued flat with body
- F3.** 40mm seam allowance glued flat with body
- T1.** Trim with **clear cream for leather finish**

## Manipulation & Dying

- OB1.** Color transition C05 - C12 start from the top

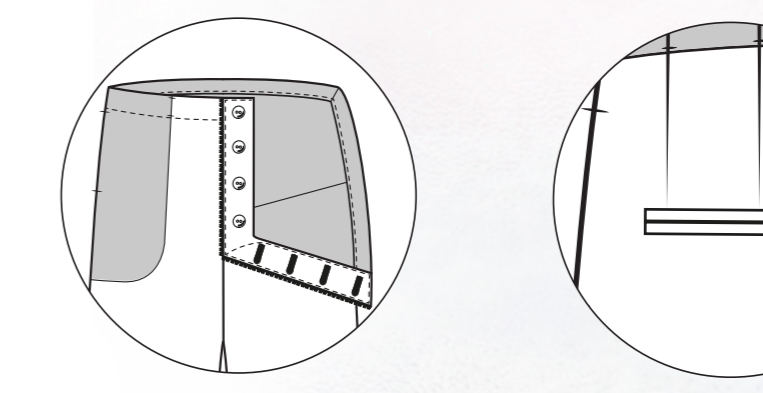
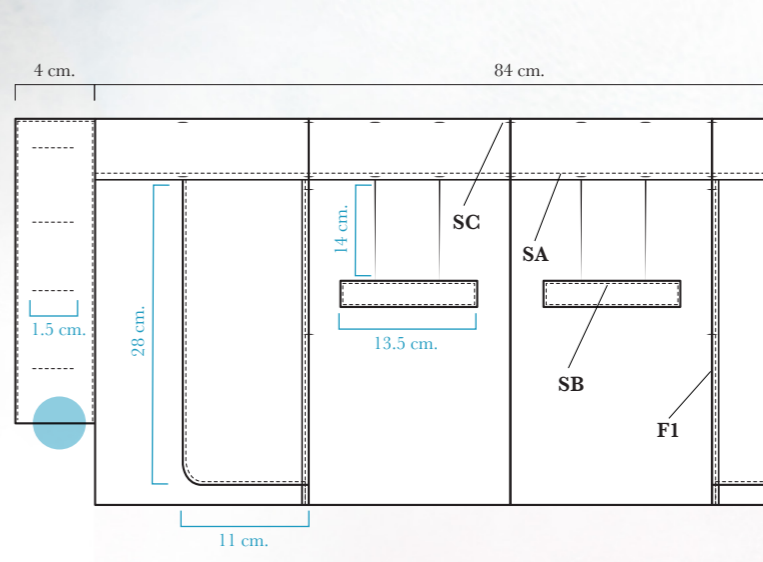
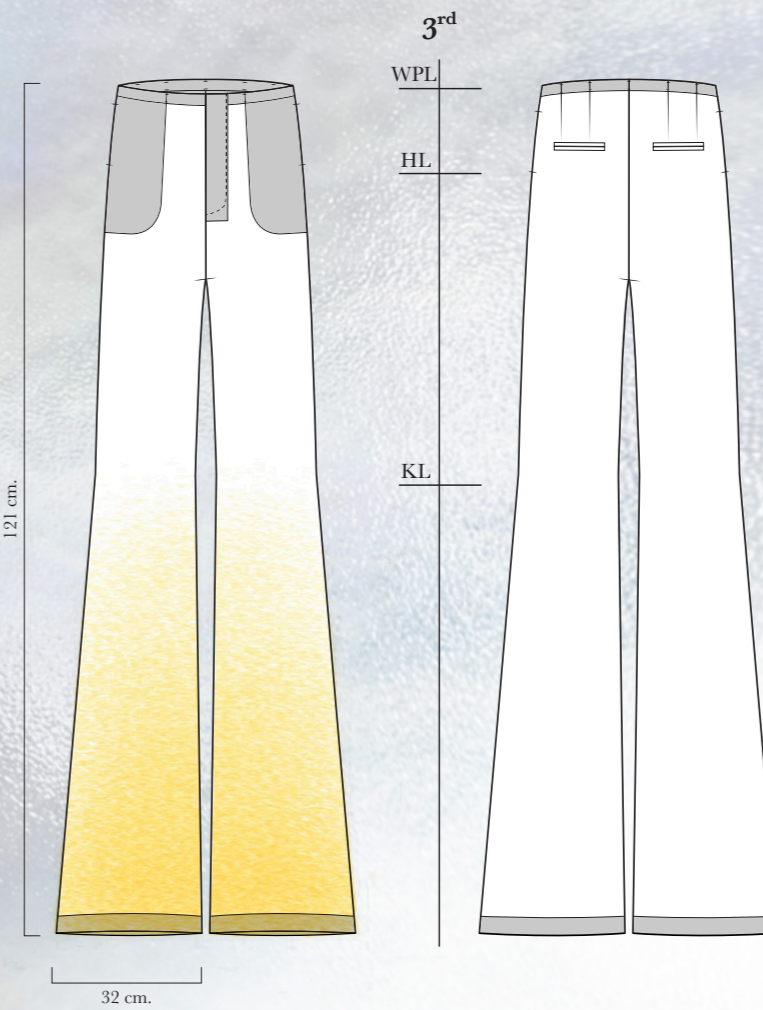

One piece selvedge cut fly  
Welt. length - 10mm width - 135mm

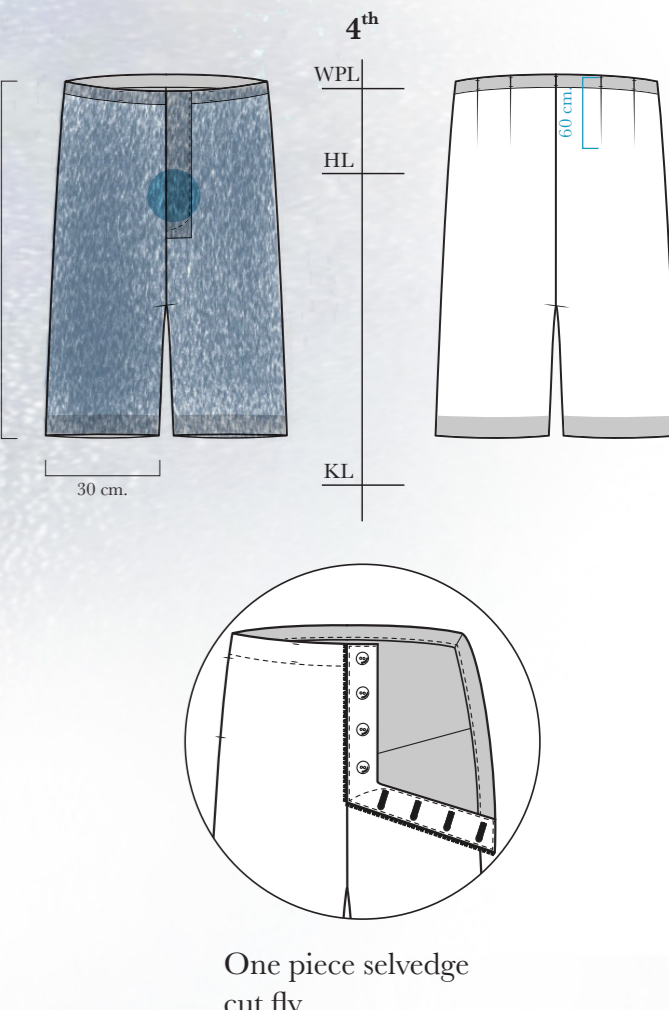

One piece selvedge cut fly

## Stitching&Distance

- SA.** Stitiched belt turned 10mm
- SB.** Stitich matchin color  
5mm
- SC.** Stitich matchin color  
3mm from the side

## Finishing

- F1.** French seam finishing
- F2.** 40mm hem hand stitched finishing
- F3.** Stitich matchin color  
7mm from the side

## Manipulation & Dying

- OB2.** Color transition C04 - C03 - C01 start from bottom
- MA1.** Manipulation on OB2, ends at KL

# Ot6 Production Chart



Outfit Description  
(outside to inside)

**1<sup>st</sup> garment**  
Semi transparent wool  
worker jacket with  
draped collar and raw  
cut pocket

+

**2<sup>nd</sup> garment**  
Indigo transparent  
wool tank top

+

**3<sup>rd</sup> garment**  
Semi transparent wool  
flared trouser

Fabric & Hardware

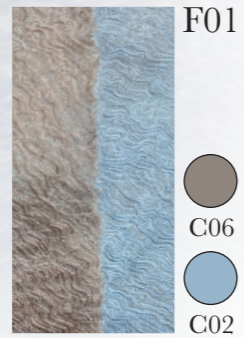

F01  
C06  
C02

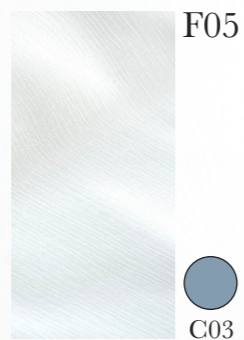

F05  
C03

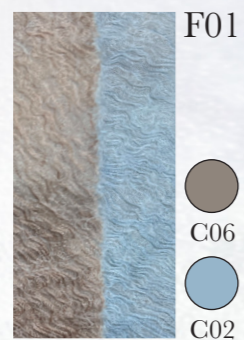

F01  
C06  
C02



H01  
C01

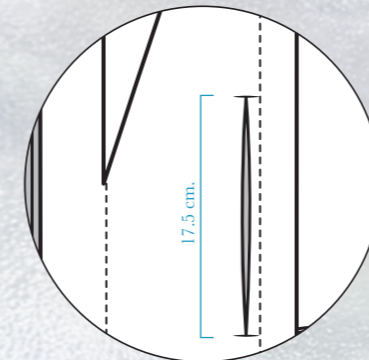
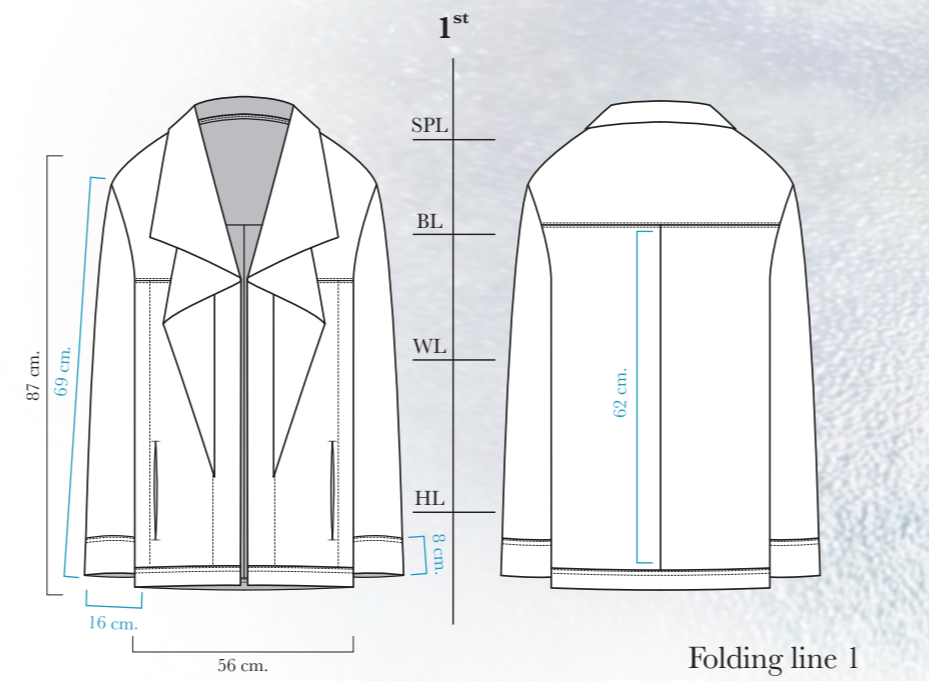

Raw cut pocket

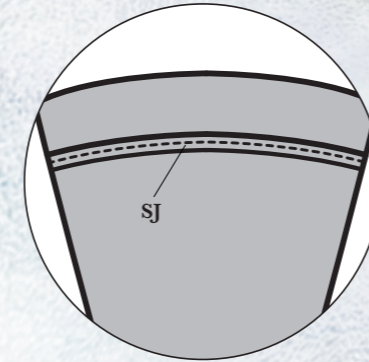

### Stitching & Distance

- SA. Stitch on the folding line stitched with matching color
- SB. Stitch 5mm from SA stitched with matching color
- SC. Stitch 5mm from the cut stitched with matching color
- SD. Stitch 5mm from the cut stitched with matching color
- SE. Stitch 5mm from the cut stitched with matching color
- SF. Stitch 5mm from the cut stitched with matching color
- SG. Stitch matching color 3mm from the side
- SH. Stitch matching color 10mm from SG
- SI. Top stitched pocket 3mm from the side
- SJ. Stitch both seam allowance 5mm downwards to body

### Finishing & Trimming

- F1. Raw cut on the edge
- F2. 3 line overlock 0.5 cm on the edge with matching color

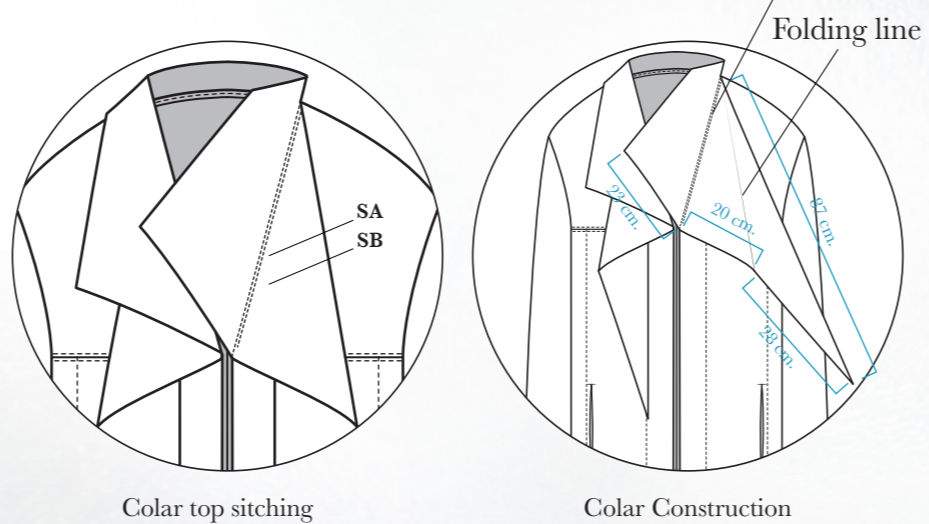

Collar top stitching

Collar Construction

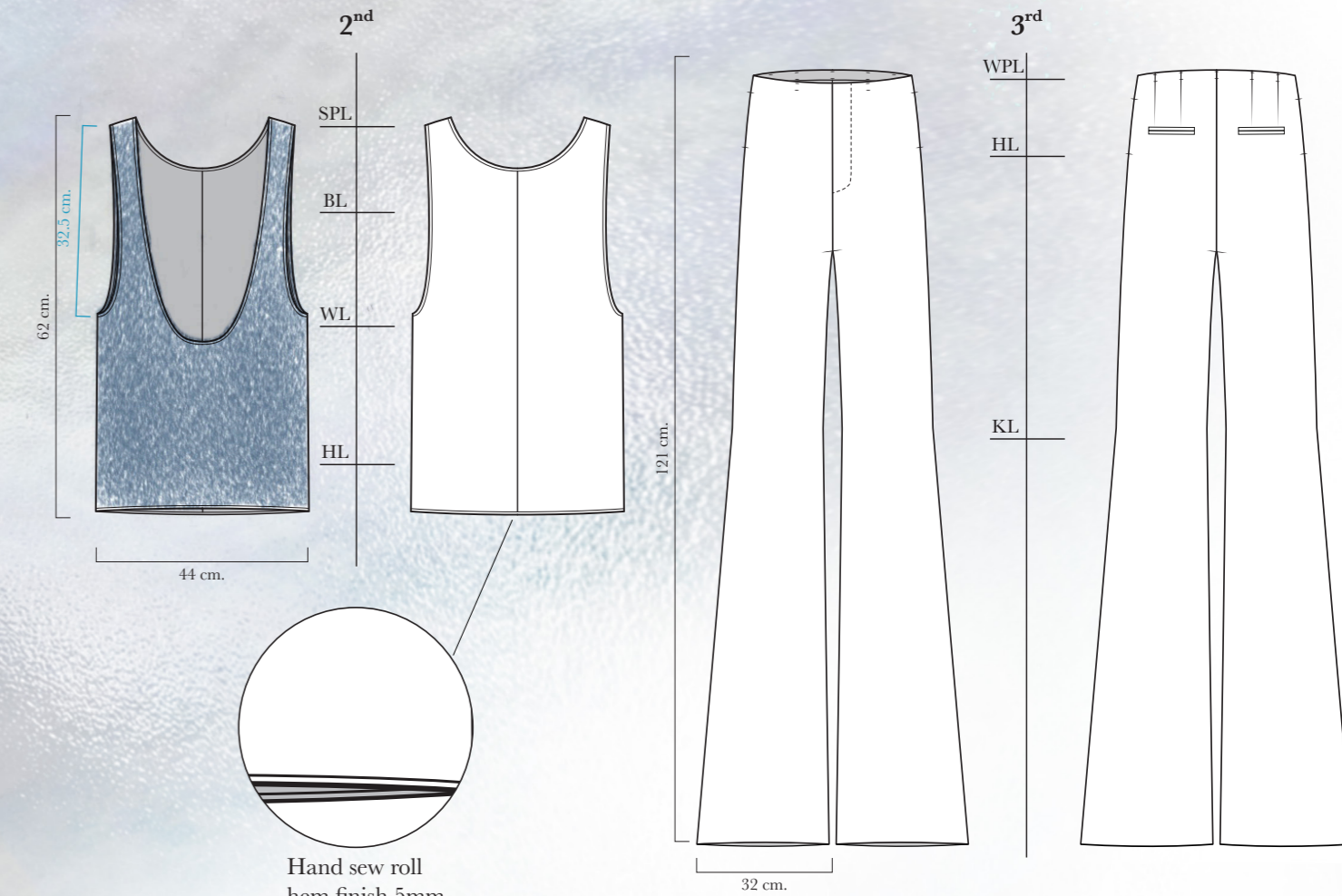
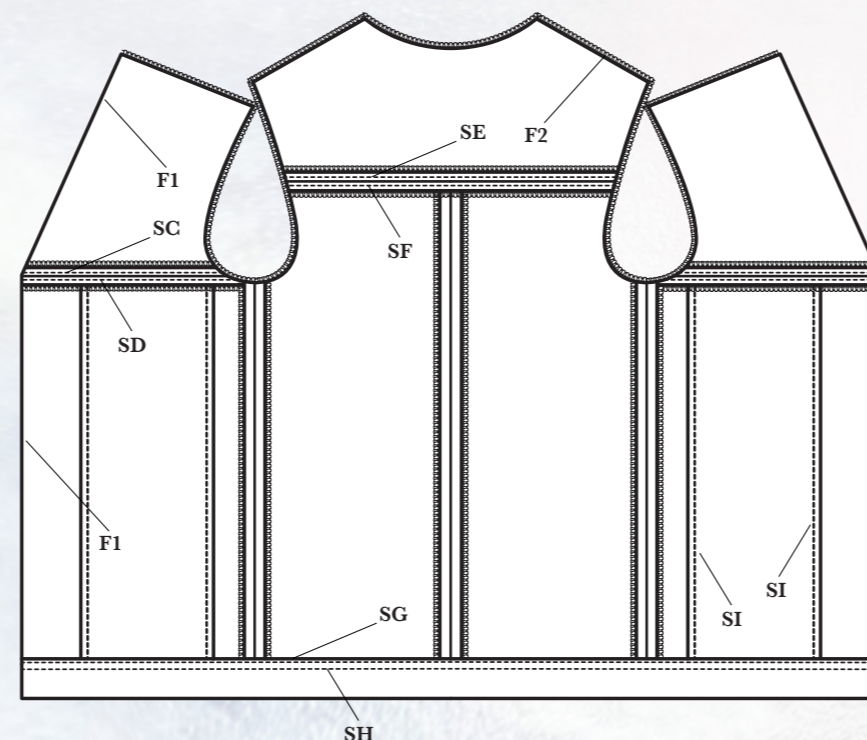

Hand sew roll hem finish 5mm

### Stitching & Distance

- SA. Stitched belt turned 10mm
- SB. Stitch matchin color 5mm
- SC. Stitch matchin color 3mm from the side

### Finishing

- F1. French seam finishing
- F2. 40mm hem hand stitched finishing
- F3. Stitch matchin color 7mm from the side

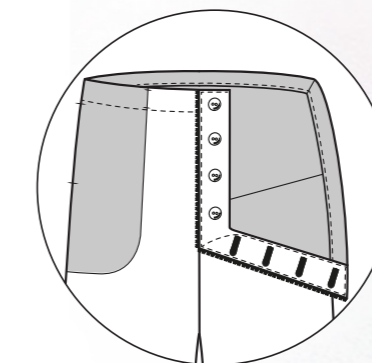

One piece selvedge cut fly

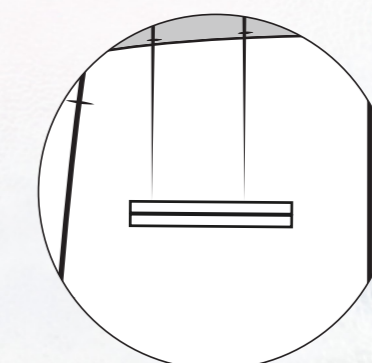

Welt. length - 10mm  
width - 135mm



*Outfit Lineup*



OT1



OT2



OT3



OT4

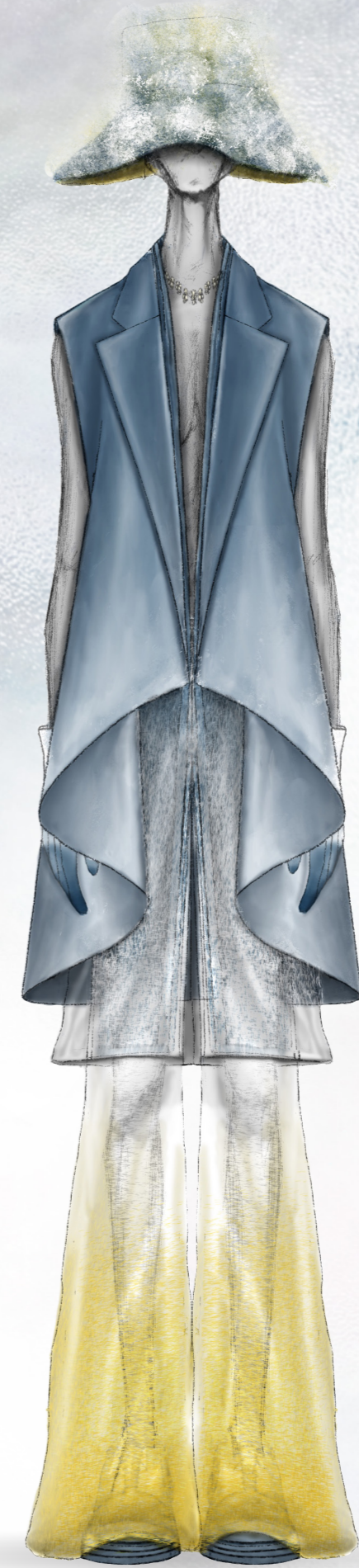

OT5



OT6

TO BE AGAIN THAT'S THE QUESTION

*Outfit Lineup*



OT1

OT3

OT2

TO BE AGAIN THAT'S THE QUESTION



OT4

OT5  
(Prototype)

OT6  
(Prototype)

