





PRESENTATION PORTFOLIO

Xiang Li

19009447

BA(Hons) Cordwainers Fashion Bags and Accessories: Product
Design and Innovation Y3

Tutor - Benjamin Hall, Eting Liu, Selina Cheong

Unit - Concept realisation

Statement of Originality

This statement is to certify that, to the best of my knowledge, this is an original piece of work. I certify that the intellectual content of this work is my own work and any sources, citations used and assistance received have been acknowledged, no section of this report has been plagiarised.

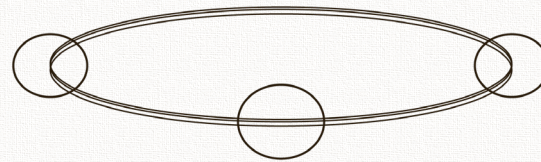

ABOUT • Ovalt - The Space



CONCEPT BOARD





COLLECTION MOOD BOARD

Food
Plating
Cutlery
Tableware
Chairs

The Table





COLOUR & MATERIAL BOARD



Cream Almond Chestnut Walnut Sage Matcha



CONSUMER BOARD



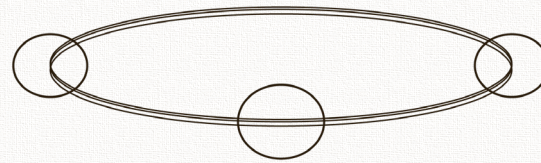

COLLECTION • THE TABLE 2024



LINE UP



THE TABLE 2024.



001



THE OLIVE

Leather clutch, Sapele wooden stand.

Statement Piece 1.0 in - The Table

Inspired by the shape of ice cream/puree on a plate, this spoon scouped olive shaped clutch has smooth texture and comfortable carry size.

The stand is transformed from a frame of a vintage dining chair, curves on all three dimensions allow the clutch to sit inside and work as a container.



002



THE ONION

Leather clutch, Sapele wooden frame.

Style number 002 in - The Table

Inspired by the shape and construction of vintage dining chair, this clutch communicates the wooden structure in leather, forming an elegant pleated effect.

The hardware is a bespoke oval shaped metal capped magnet inspired by THE OLIVE.



003

THE RACK

Leather handbag, Leather and Sapele wooden handle.

Style number 003 in - The Table

Inspired by the shape of vintage coffee table, combining the idea of a "rack" of ingredients, this handbag is a large structured bag that showcases volume.





004



THE SHORTBREAD

Leather cardholder, wood and metal decoration.

Style number 004 in - The Table

Inspired from dessert plating and leg structures of industrial style vintage chairs, this cardholder is a unique small leather good in the collection that act as the icing on the cake.

It's smooth tecture and rounded shape conveys a warm and calming atmosphere to the owner.



005



THE HALIBUT

Leather crossbody bag.

Statement Piece 2.0 in - The Table

The second statement piece in the collection is a more practical model. Inspired by food plating and ingredient composition of modern restaurants, this crossbody bag has sculptural shapes and popping details of decorative half spheres.

THE PLATE

Leather shoulder bag.

Style number 006 in - The Table

The last piece in the collection is a variation of a large tote bag. Inspired by food plating, different from THE HALIBUT, THE PLATE includes all component from the furniture to the ingredients.

With wood and metal decorations, this bag shows a quiet style with a pop of vibrance.

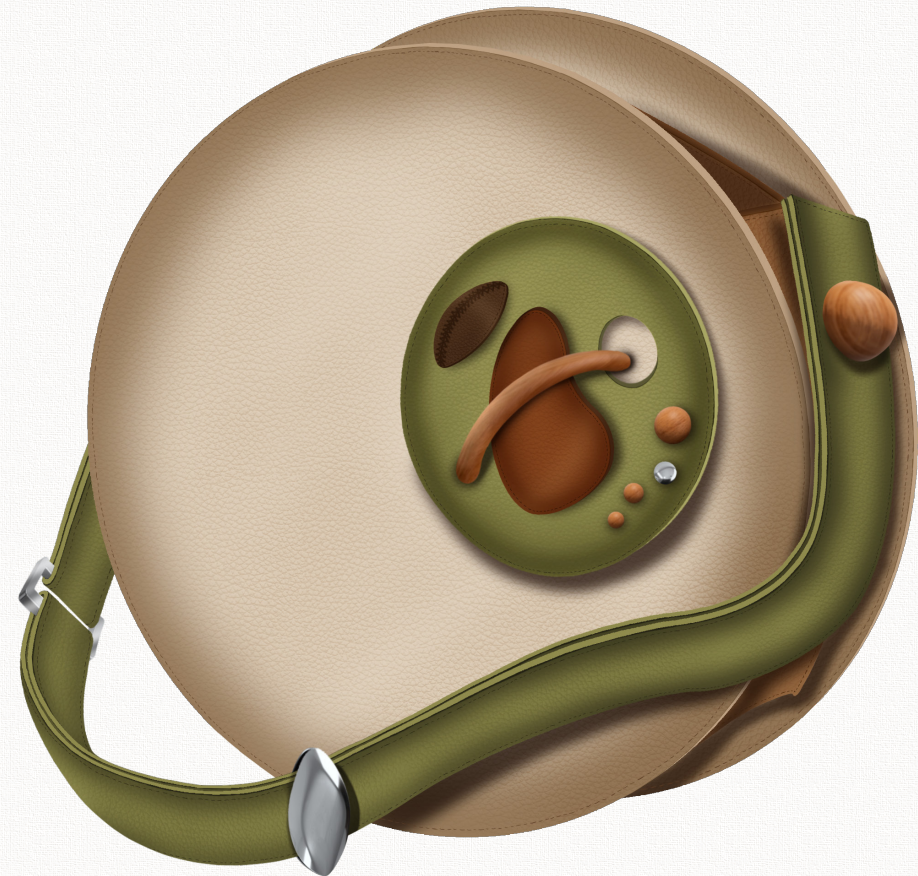



RANGE PLAN

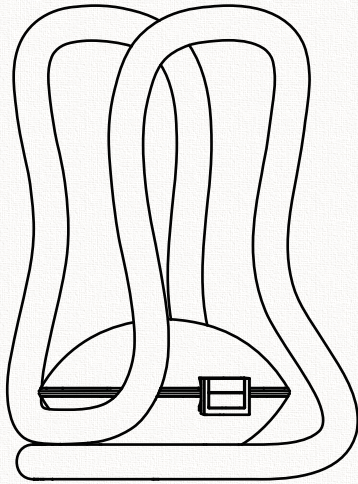

☆ THE OLIVE

£825

Shell: 190×105×85
Stand: 280×200×140

 Walnut



Zinc alloy ip lock polished chrome
Zinc alloy hinge polished chrome

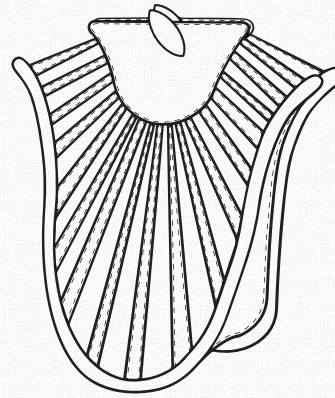

THE ONION

£495

250×160×100

 Chestnut  Matcha



Zinc alloy oval shell magnet
polished chrome ×2

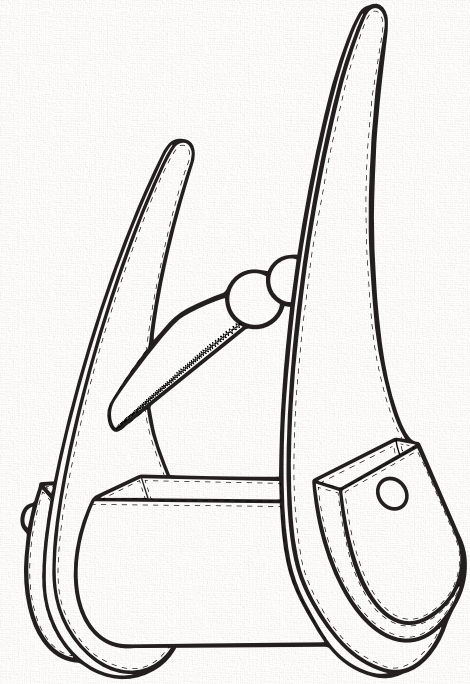

THE ONION

£695

450×300×180

 Chestnut  Almond



Zinc alloy half sphere shell magnet
polished chrome ×2

Unit: mm



RANGE PLAN

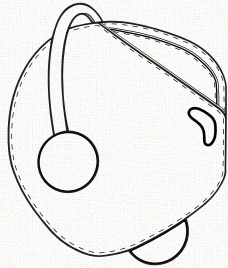

THE SHORTBREAD

£120

110×90×35

Matcha Almond Chestnut



Zinc alloy organic shaped stud polished chrome

Unit: mm

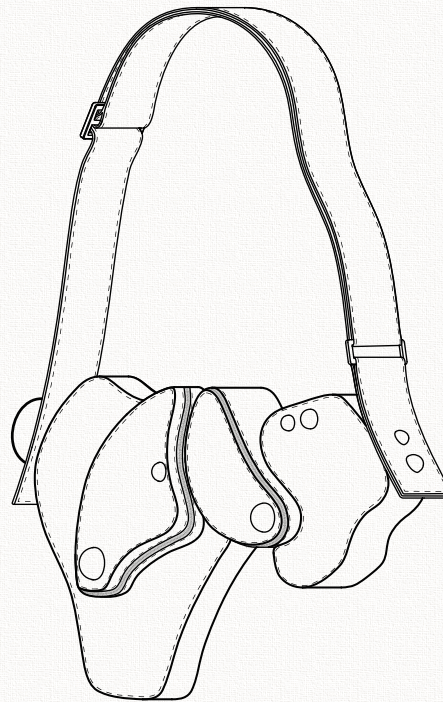

★ THE HALIBUT

£525

420×250×90

Chestnut



Zinc alloy half sphere stud polished chrome ×5
Zinc alloy rectangle adjust ring ×1
Zinc alloy rectangle ring ×1
8mm metal rivets silver ×9
YKK No.5 metal teeth zip ×4

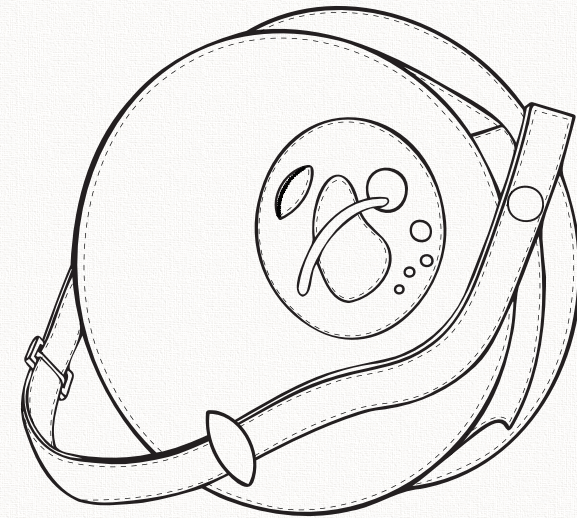

THE ONION

£650

450×420×90

Walnut Almond



Zinc alloy half sphere stud polished chrome ×1
Zinc alloy rectangle ring ×1
Zinc alloy oval shaped buckle polished chrome

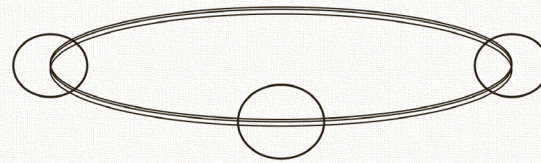

DEVELOPMENT • THE TABLE 2024



001 - THE OLIVE



OVALT

DESCRIPTION: The Table - THE OLIVE

STYLE NO: ovalt_001

SEASON: 2024

DESIGNER: Xiang Li

DATE: MAY 2024

MATERIALS

MAIN BODY:

London Tan, Dyed Through,
Vegetable tanned double shoulder



TRIM: Raw edge

LINING: Synthetic leather (back)
white



REINFORCEMENT

INNER SHELL: PLA White



LIP: Sapele wood



HARDWARE

LOCK: Zinc alloy flip lock
polished chrome



FITTING: Zinc alloy hinge
polished chrome



LEFT 3/4 VIEW

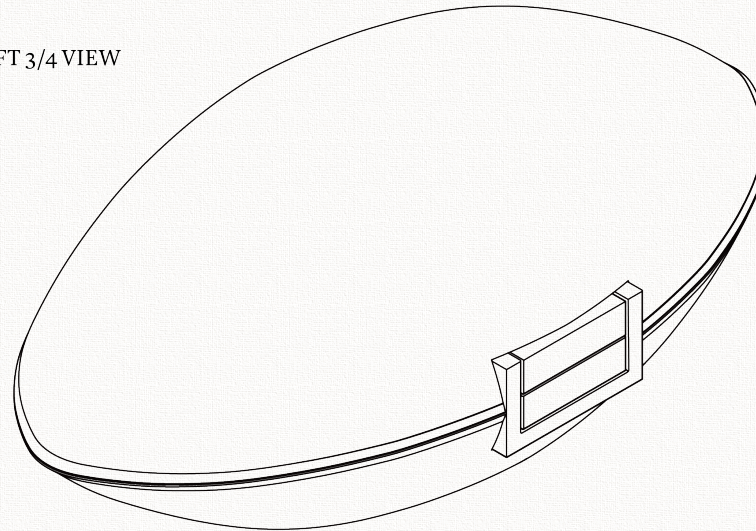

The OLIVE clutch is structured by moulding a layer of leather on the outer surface of two 3d printed shells. The connecting surfaces are covered with a 2mm thick sapele wood lip and fixed and connected with a metal flip lock and a hinge.

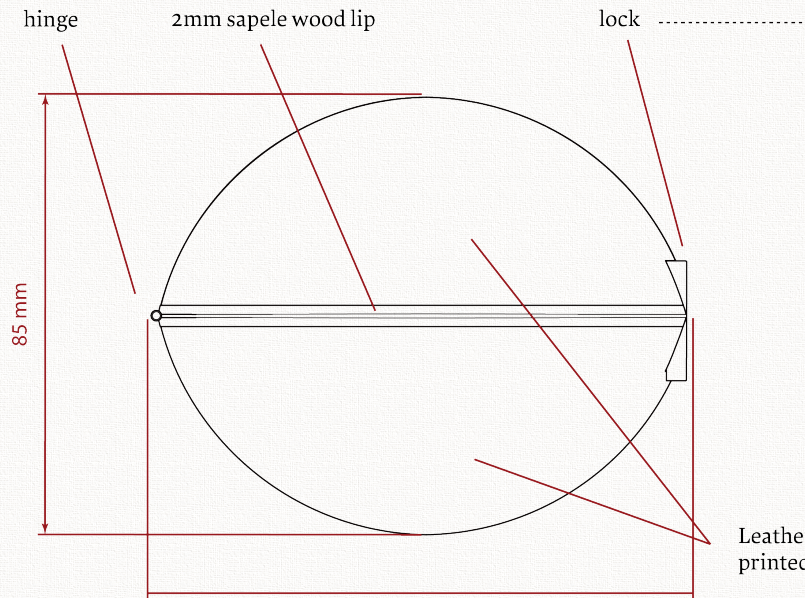

The flip lock consists of a 4mm thick flip and two 2mm thick lock parts that can be clipped together by putting clicking the notch on the flip to the raised bit at the bottom of the lock.

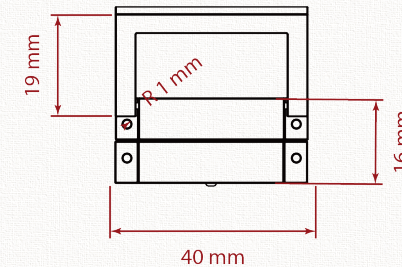
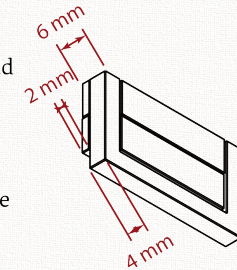

It is secured by four 1mm screws separately on the top and bottom halves to allow the opening of the clutch.

Leather covered 3d printed shell

SCALE 1:1 A3

105 mm
LEFTVIEW

OVALT

DESCRIPTION: The Table - THE OLIVE

STYLE NO: ovalt_001

SEASON: 2024

DESIGNER: Xiang Li

DATE: MAY 2024

MATERIALS

MAIN BODY:
London Tan, Dyed Through,
Vegetable tanned double shoulder



TRIM: Raw edge

LINING: Synthetic leather (back)
white



REINFORCEMENT

INNER SHELL: PLA White



LIP: Sapele wood



HARDWARE

LOCK: Zinc alloy flip lock
polished chrome



FITTING: Zinc alloy hinge
polished chrome

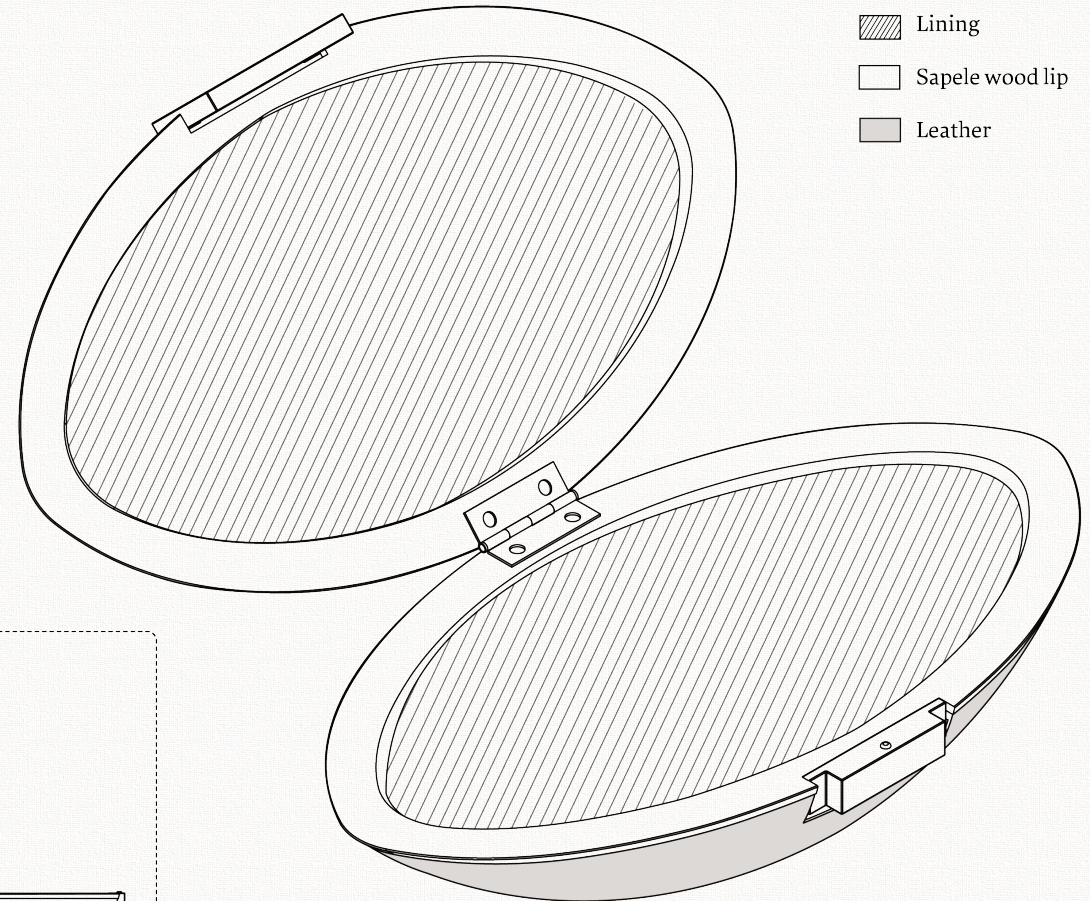
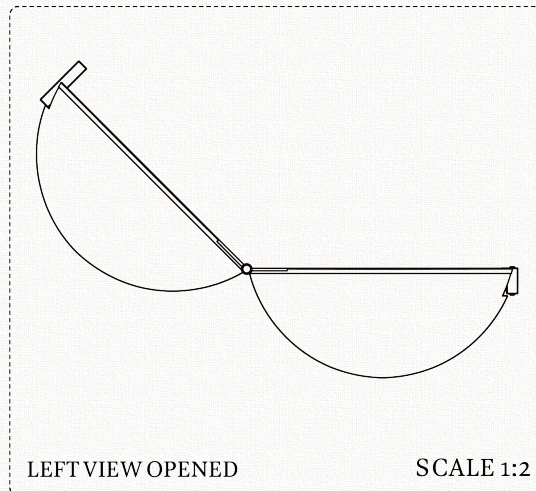
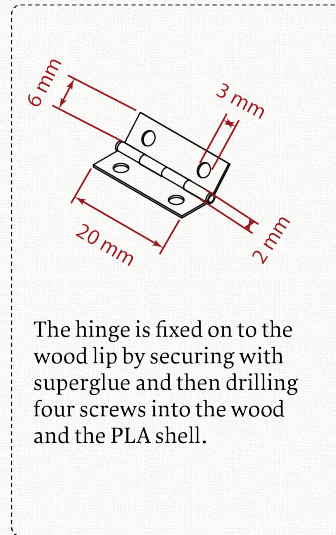

SCALE 1:1 A3

OVALT

DESCRIPTION: The Table - THE OLIVE

STYLE NO: ovalt_001

SEASON: 2024

DESIGNER: Xiang Li

DATE: MAY 2024

MATERIALS

MAIN BODY:
London Tan, Dyed Through,
Vegetable tanned double shoulder



TRIM: Raw edge

LINING: Synthetic leather (back)
white



REINFORCEMENT

INNER SHELL: PLA White



LIP: Sapele wood



HARDWARE

LOCK: Zinc alloy flip lock
polished chrome



FITTING: Zinc alloy hinge
polished chrome



□ 3D printed PLA shell

▨ Sapele wood lip

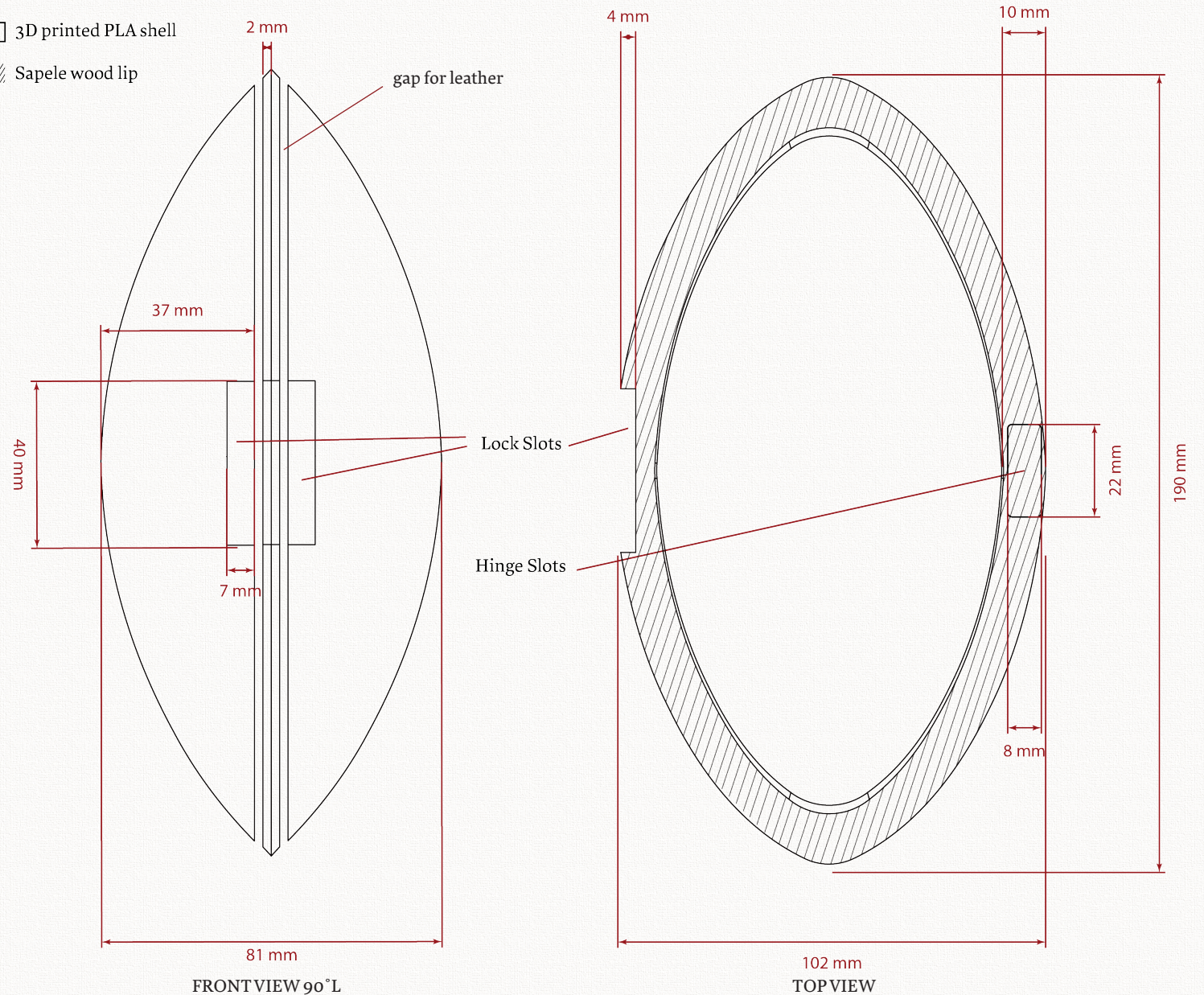

FRONT VIEW 90°L

TOP VIEW

SCALE 1:1 A3

OVALT

DESCRIPTION: The Table - THE OLIVE

STYLE NO: ovalt_001

SEASON: 2024

DESIGNER: Xiang Li

DATE: MAY 2024

MATERIALS

MAIN BODY:
London Tan, Dyed Through,
Vegetable tanned double shoulder



TRIM: Raw edge

LINING: Synthetic leather (back)
white



REINFORCEMENT

INNER SHELL: PLA White



LIP: Sapele wood



HARDWARE

LOCK: Zinc alloy flip lock
polished chrome



FITTING: Zinc alloy hinge
polished chrome



FRONT VIEW SPLIT

The stand /handle is CNC milled in sapele wood in two symmetrical parts.

The two parts are connected at the base with built-in tenon and mortise binding. Put wood glue in and apply pressure to secure the connecting parts in the shape of the design.

Curves perform on all three dimensions of the handle.

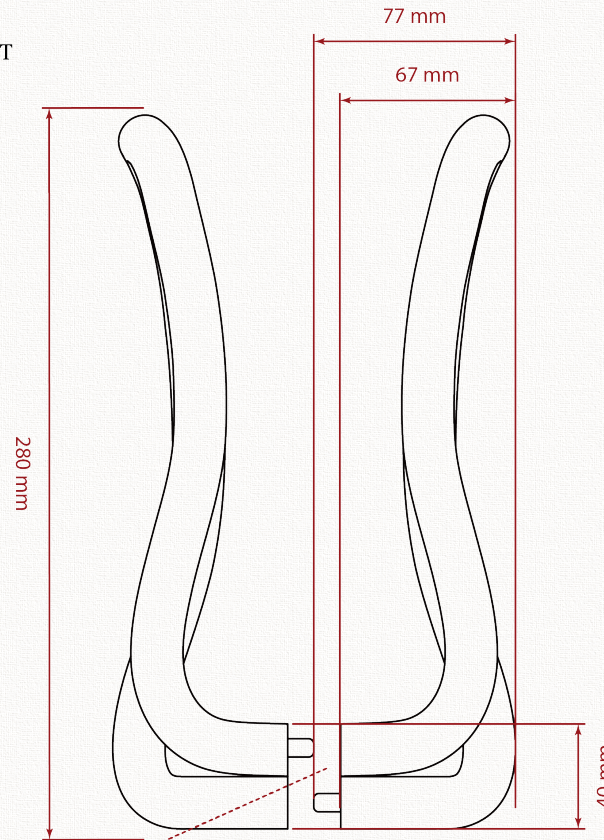

The two layers of wood meet at the bottom of the stand like this, with a slight gap in the middle.

Slots for the olive clutch to sit in. Slightly carved the surface of the handle tube in oval shapes to gain a flatter surface for the clutch placement.

BACK 3/4 VIEW

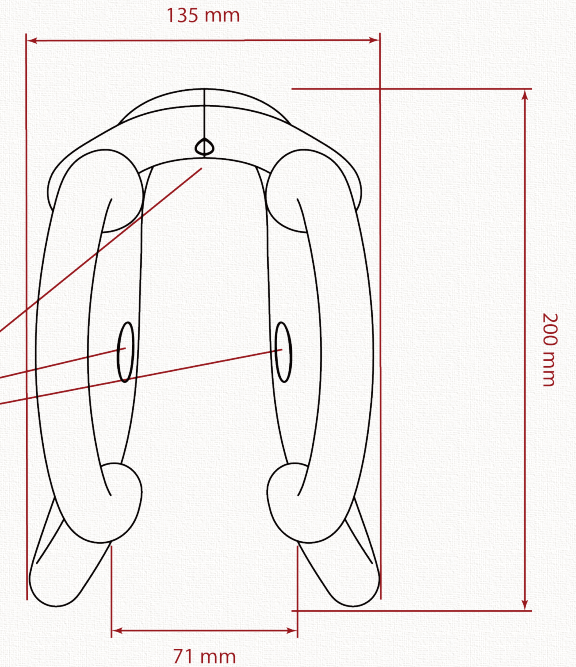
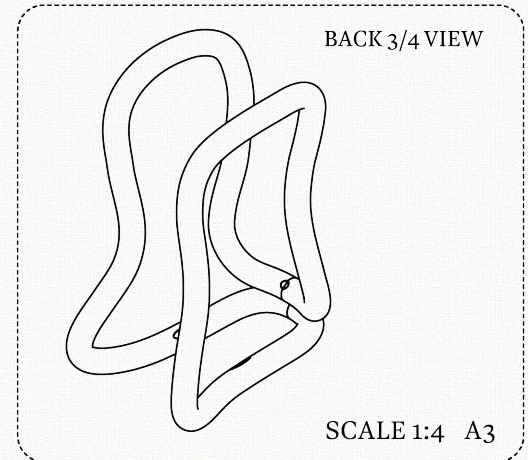

TOPVIEW

SCALE 1:2 A3



005 - THE HALIBUT



OVALT

DESCRIPTION: The Table - THE HALIBUT

STYLE NO: ovalt_005

SEASON: 2024

DESIGNER: Xiang Li

DATE: MAY 2024

MATERIALS

MAIN BODY:
London Tan, Dyed Through,
Vegetable tanned double shoulder

TRIM: Raw edge

LINING: Heavy duty 600 denier
canvas Ivory

HARDWARE & FITTINGS

STUD: Zinc alloy half sphere
studs polished chrome

RIVET: Metal 8mm rivets
silver

DECORATION: Sapele wood

D-RING: Zinc alloy rectangle
d-ring polished chrome

ZIP: YKK No.5 metal teeth
continuous zip dark brown
with silver teeth

YKK silver zip runner

GENERAL NOTES

This whole bag has only a few actual
stitches for the zips and the strap, while
all other parts are glued to construct the
structure.

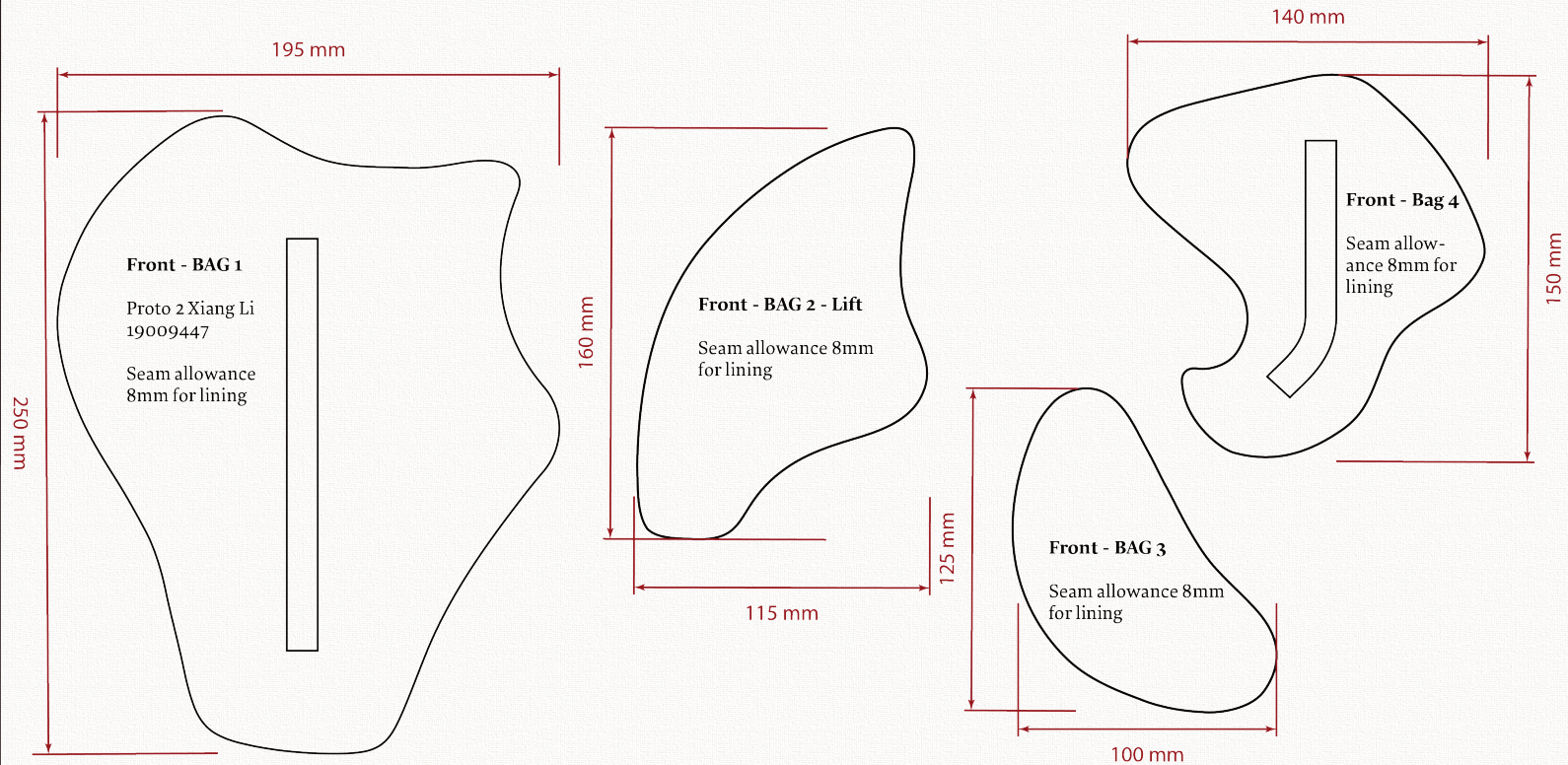

NET Patterns
and accurate
dimensions

GUSSET - BAG 1 720mm × 40mm Seam allowance 8mm - shell and lining

GUSSET - BAG 2 470mm × 15mm × 2 Seam allowance 8mm - shell and lining

GUSSET - BAG 3 360mm × 65mm
Seam allowance 8mm - shell and lining

GUSSET - BAG 4 470mm × 50mm
Seam allowance 8mm - shell and lining

SCALE 1:4 A3

SCALE 1:2 A3

OVALT

DESCRIPTION: The Table - THE HALIBUT

STYLE NO: ovalt_005

SEASON: 2024

DESIGNER: Xiang Li

DATE: MAY 2024

MATERIALS

MAIN BODY:
London Tan, Dyed Through,
Vegtable tanned double shoulder



TRIM: Raw edge

LINING: Heavy duty 600 denier
canvas Ivory



HARDWARE & FITTINGS

STUD: Zinc alloy half sphere
studs polished chrome



RIVET: Metal 8mm rivets
silver



DECORATION: Sapele wood



D-RING: Zinc alloy rectangle
d-ring polished chrome



ZIP: YKK No.5 metal teeth
continuous zip dark brown
with silver teeth



YKK silver zip runner



GENERAL NOTES

This whole bag has only a few actual
stitches for the zips and the strap, while
all other parts are glued to construct the
structure.

Stitch length: 4mm
Thread colour: dark brown

Top stitch with dark
brown thread, 4mm
stitch length, 3mm
margin for securing
the all-around zips
to the shell panels
and the lining pieces
of BAG 2 and BAG 3.

Dummy stitches
(top stitch) with
dark brown
thread, 4mm
stitch length,
3mm margin on
all front and back
panels from BAG
1 to BAG 4

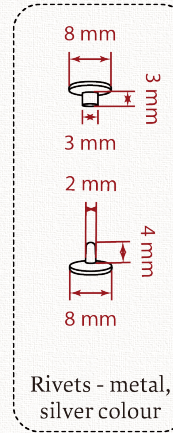

The four component are riveted together to hold the
shape. BAG 1, BAG 3 and BAG 4 are on the same level
when laid flat. These three are connected to each
other with two rivets each on their aligning gussets.

BAG 2 is lifted from the other three and is connected
to BAG 1 through two rivets on the back panel of
BAG2 and the front panel of BAG 1.

The construction order is:

1. rivet back of BAG 2 to front of BAG 1
2. attach gussets onto BAG 1, 3, 4
3. punch and rivet BAG 1, 3, 4
4. construct the rest of BAG 2 and glue it to its back
panel

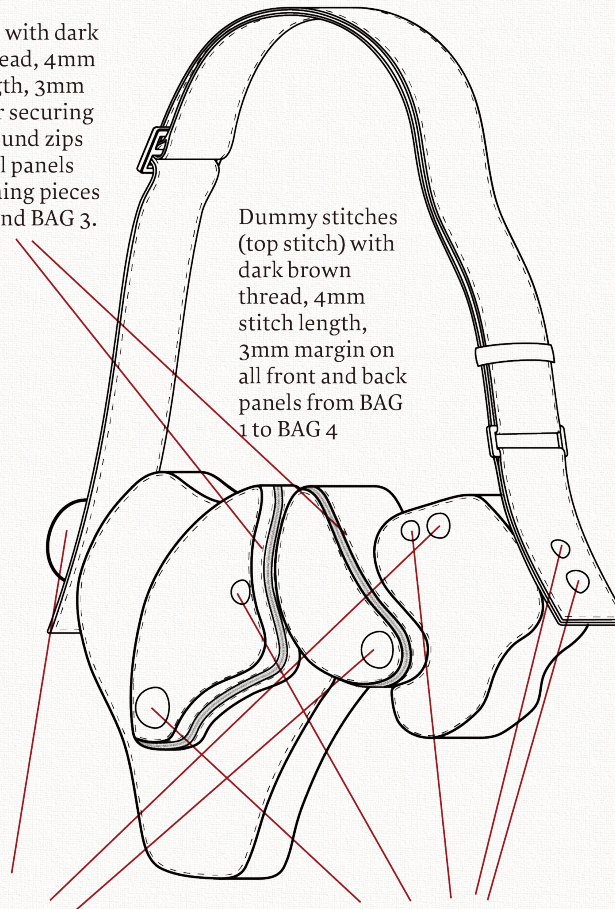

Sapele wood half sphere
decorative screw caps

Zinc alloy polished chrome
half sphere decorative screw
caps

RIGHT FRONT 3/4 VIEW

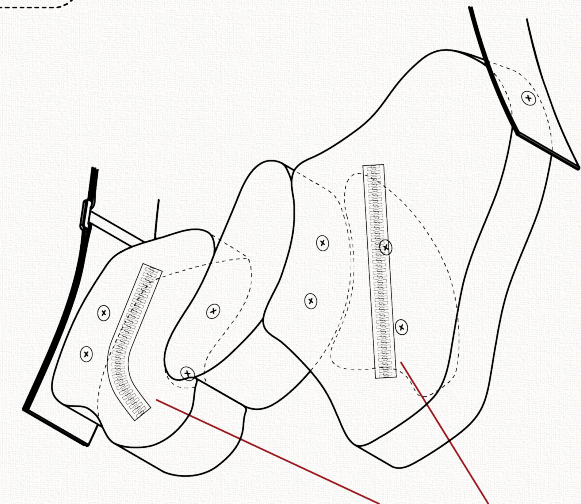

Zips in the back panels of BAG 1 and
BAG 4, 4mm top stitch with 2mm
margin all around.

RIGHT BACK 3/4 VIEW - STRUCTURE

SCALE 1:3 A3

OVALT

DESCRIPTION: The Table - THE HALIBUT

STYLE NO: ovalt_005

SEASON: 2024

DESIGNER: Xiang Li

DATE: MAY 2024

MATERIALS

MAIN BODY:

London Tan, Dyed Through,
Vegetable tanned double shoulder



TRIM: Raw edge

LINING: Heavy duty 600 denier
canvas Ivory



HARDWARE & FITTINGS

STUD: Zinc alloy half sphere
studs polished chrome



RIVET: Metal 8mm rivets
silver



DECORATION: Sapele wood



D-RING: Zinc alloy rectangle
d-ring polished chrome



ZIP: YKK No.5 metal teeth
continuous zip dark brown
with silver teeth



YKK silver zip runner



GENERAL NOTES

This whole bag has only a few actual
stitches for the zips and the strap, while
all other parts are glued to construct the
structure.

Stitch length: 4mm
Thread colour: dark brown

SCALE 1:1 A3

Layer construction from top to
bottom:

1. Shell material - leather
2. Folded edge of lining
3. Flat head of screw
4. Lining

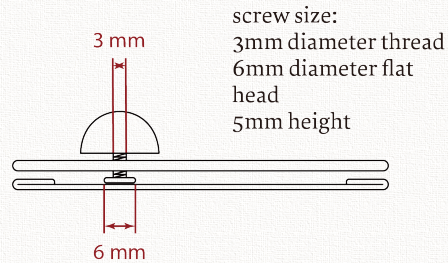

BOTTOM VIEW

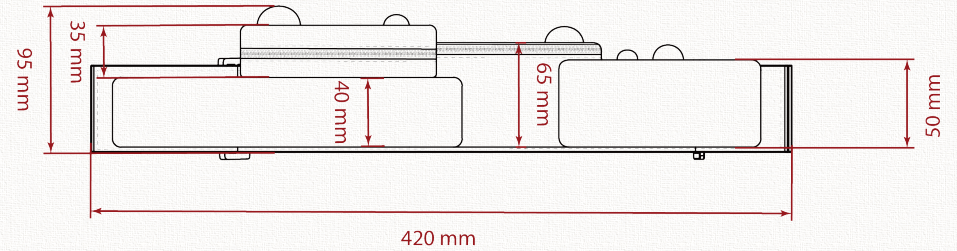

SCALE 1:1 A3

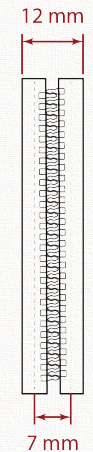

YKK No.5 metal
zipper with silver
slider.
4mm top stitch
with 2mm margin
along the teeth.

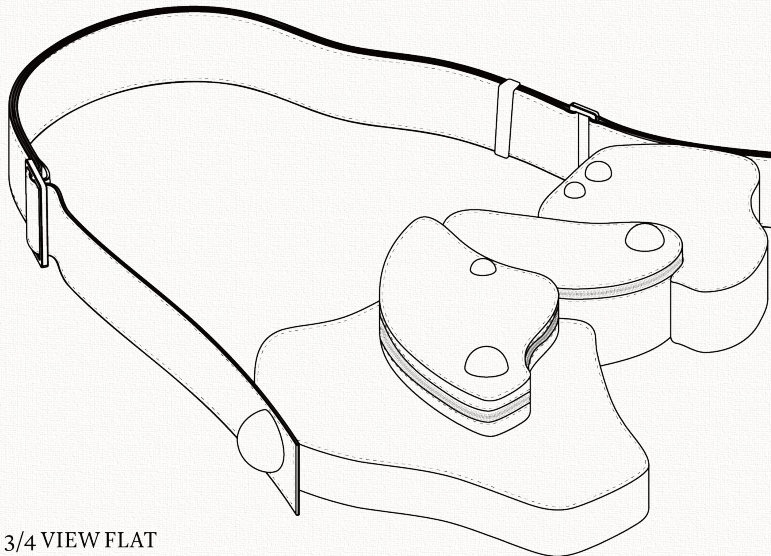

LEFT 3/4 VIEW FLAT

SCALE 1:3 A3

OVALT

DESCRIPTION: The Table - THE HALIBUT

STYLE NO: ovalt_005

SEASON: 2024

DESIGNER: Xiang Li

DATE: MAY 2024

MATERIALS

MAIN BODY:
London Tan, Dyed Through,
Vegtable tanned double shoulder



TRIM: Raw edge

LINING: Heavy duty 600 denier
canvas Ivory



HARDWARE & FITTINGS

STUD: Zinc alloy half sphere
studs polished chrome



RIVET: Metal 8mm rivets
silver



DECORATION: Sapele wood



D-RING: Zinc alloy rectangle
d-ring polished chrome



ZIP: YKK No.5 metal teeth
continuous zip dark brown
with silver teeth



YKK silver zip runner



GENERAL NOTES

This whole bag has only a few actual
stitches for the zips and the strap, while
all other parts are glued to construct the
structure.

Stitch length: 4mm
Thread colour: dark brown

Ends of Strap & Hardware

FRONT VIEW

Combining
two layers
of 1mm
leather, this
bag has a
thin strap
that is 2mm
thick.

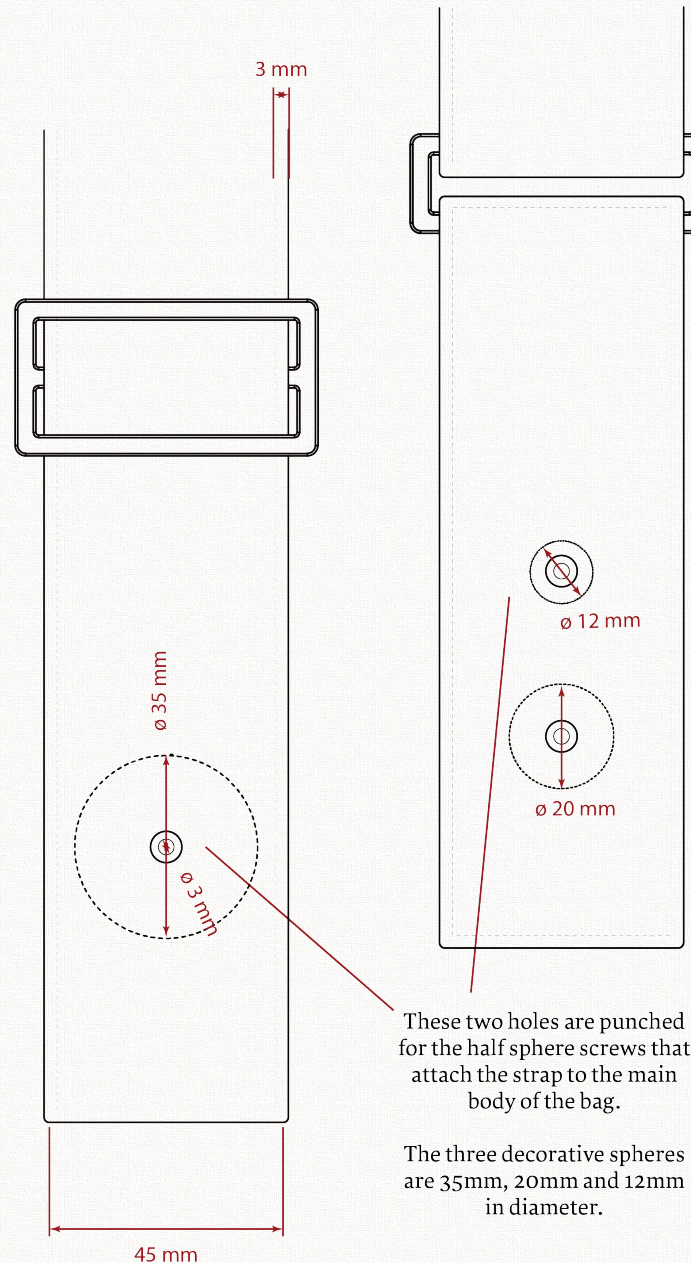
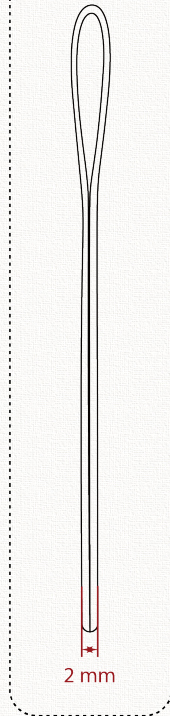

Adjust ring
thickness of frame: 4mm

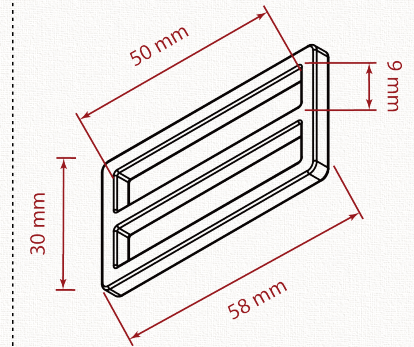

RIGHT 3/4 VIEW

Rectangle ring
thickness of frame: 4mm

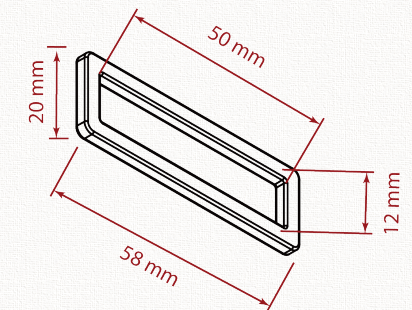

LEFT 3/4 VIEW

SCALE 1:1 A3

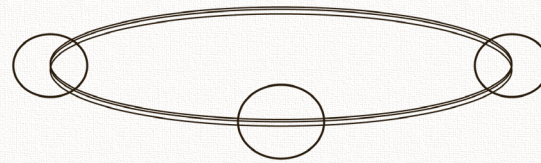

MARKETING • Ovalt - The Space



LOOKBOOK

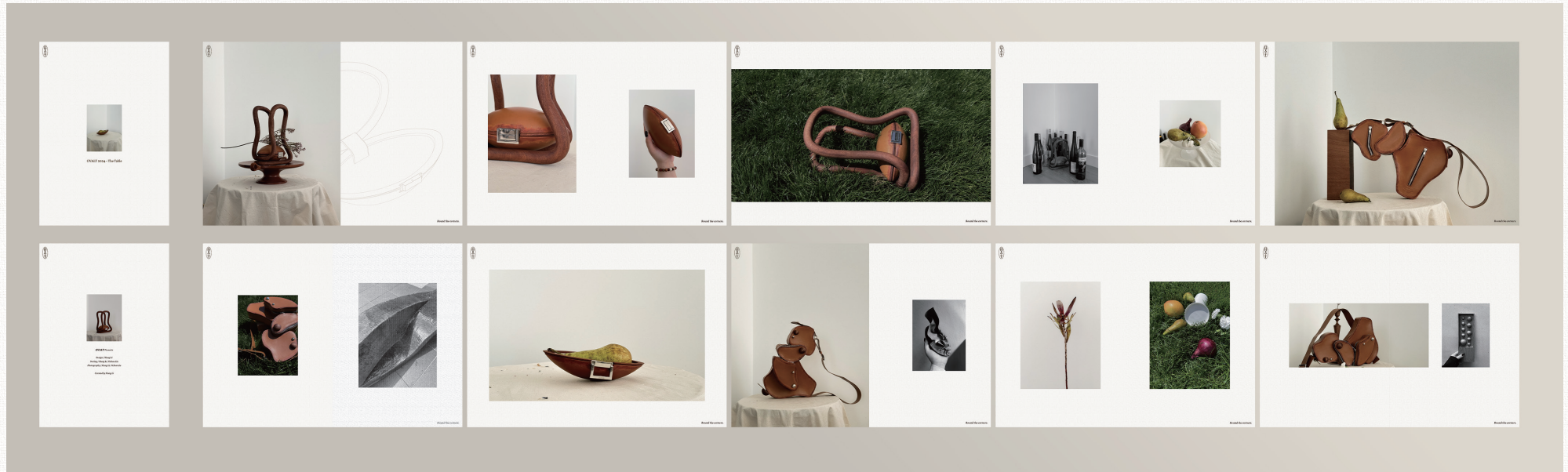



UNBOXING

Textured paper shopper

Product Tag

Round the corners.

Dust Bag

Correspondence card



ONLINE CAMPAIGN

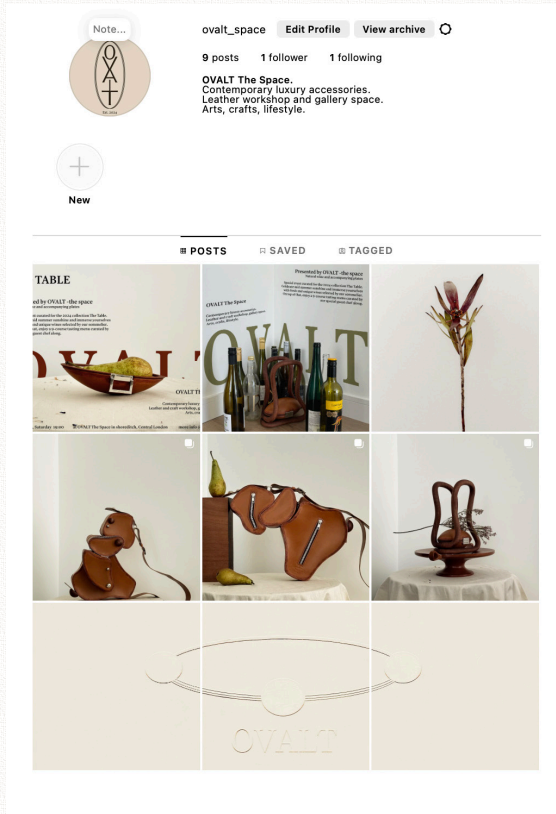

Online campaign of tasting event curated for the collection The Table. The event will run at the showroom and workspace of OVALT The Space in central London. We will collaborate with guest sommelier and guest chef in order to present a high quality table.





EVENT SPACE PLAN

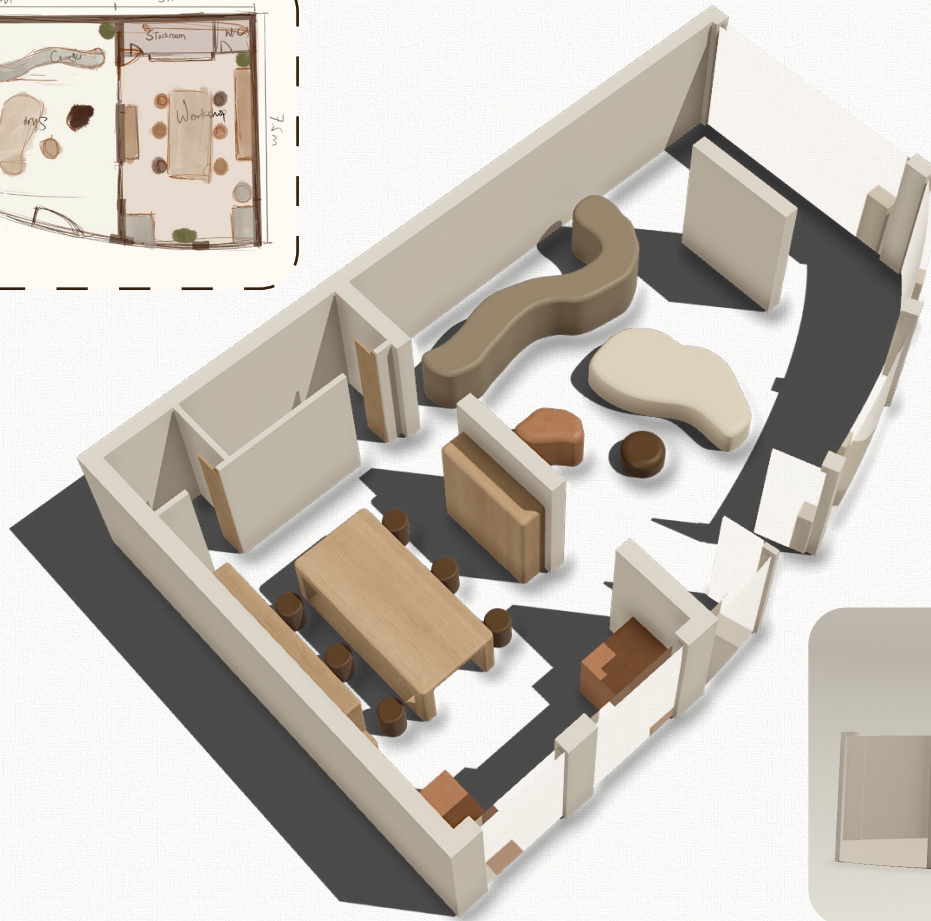

Conceptual model and planning of the workspace and the event space. The whole space is split into two parts, the showroom and the workshop. The showroom space contains the shop, gallery, and the cafe. The events will mostly be held in this space with different layouts curated for every other event.

OVALT - The Space

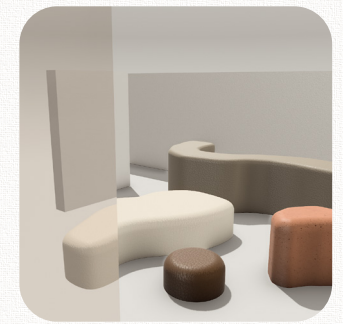
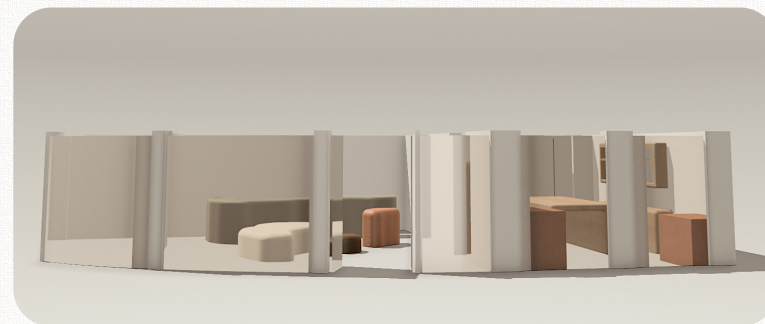



Round the corners.