

Professional Brief: Inspiration and Design Concept for Contemporary Leather Armor

Designer Information

Name: **OCHOM EDDIE LOUIS**

Location: **Uganda**

Education: **First-Class Degree in Fashion and Design, Makerere University**

Aspiration: **Costume Designer**

Project Overview:

The project involves the creation of a contemporary leather armor for women, inspired by medieval women's leather armor. This piece will be designed for use in plays and dramas, providing an ancient aesthetic combined with modern fashion elements. The goal is to showcase this piece in the Real Leather Stay Different Competition 2024, highlighting the fusion of historical inspiration with contemporary design.

Source of Inspiration:

The primary inspiration for this project comes from the functional yet elegant leather armors worn by women during the medieval period. These armors were characterized by their durability, intricate designs, and the ability to provide protection while allowing mobility. Key elements include:

Material: Authentic leather, known for its strength and flexibility.

Design: Intricate patterns, often featuring embossing and tooling.

Structure: Protective yet form-fitting, allowing freedom of movement.

Design Concept:

The contemporary reinterpretation of this medieval armor will integrate the following modern elements:

Silhouette: A well-tailored fit that accentuates the female form while retaining the protective essence of the armor.

Functionality: Lightweight and breathable leather, ensuring comfort during extended wear.

Aesthetics: A blend of medieval design motifs with modern fashion trends, such as asymmetrical cuts and bold color accents.

Versatility: The armor will be designed to be versatile, suitable for various roles in plays and dramas, and adaptable for different body types.

Design Features:

Material Selection: High-quality, ethically sourced leather that offers both durability and flexibility.

Embossing and Tooling: Detailed embossing inspired by medieval patterns, combined with contemporary geometric designs.

Color Palette: A combination of traditional brown vibrant color for a striking visual impact.

Construction Techniques: Modern stitching methods combined with historical techniques to ensure both authenticity and durability.

Functional Elements: Adjustable straps and lacing to ensure a perfect fit, along with strategically placed padding for added comfort and protection.

Target Audience:

The primary audience for this contemporary leather armor includes:

Actors and Performers: Women participating in historical plays, dramas, and reenactments.

Fashion Enthusiasts: Individuals interested in unique, historically inspired fashion pieces.

Costume Designers: Professionals seeking inspiration and innovative designs for theatrical productions.

Project Goals:

Innovation: To create a unique fusion of medieval and modern design elements, showcasing the versatility of leather as a fashion material.

Authenticity: To maintain the historical integrity of the inspiration while introducing modern aesthetics and functionality.

Competition Success: To stand out in the Real Leather Stay Different Competition 2024 by presenting a design that is both original and wearable.

Conclusion:

This project aims to bring the beauty and functionality of medieval women's leather armor into the contemporary fashion scene. By combining historical inspiration with modern design techniques, OCHOM EDDIE LOUIS seeks to create a piece that is both timeless and avant-garde, suitable for the stage and beyond.

Contact Information:

Email: [eddielouisocho@gmail.com]

Phone: [0785824287]

This brief outline the inspiration, design concept, and goals for your contemporary leather armor project, providing a clear and professional presentation for the Real Leather Stay Different Competition 2024.

STORY BOARD/ SOURCES OF INSPIRATION

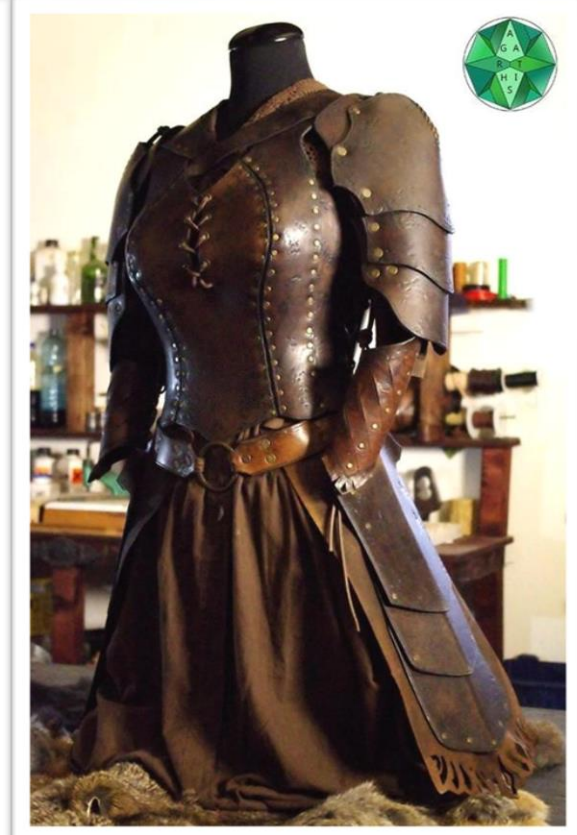
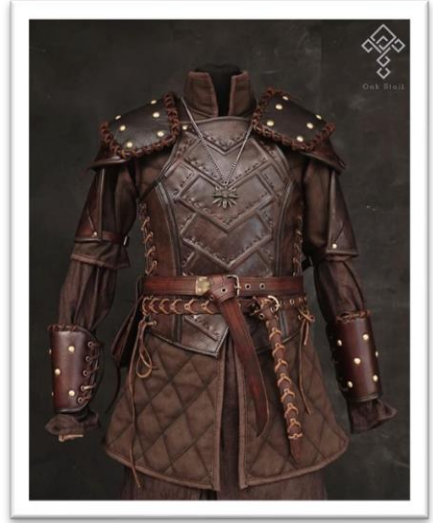
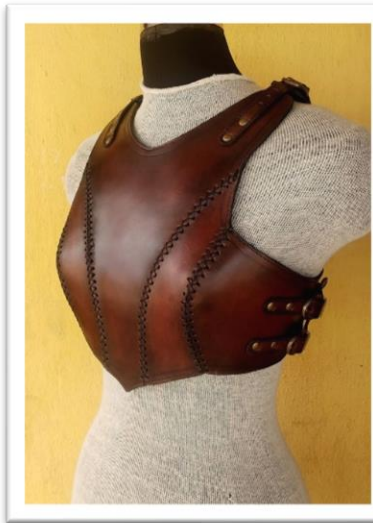

Design development.

A design for a bustier corset and a neck corset.

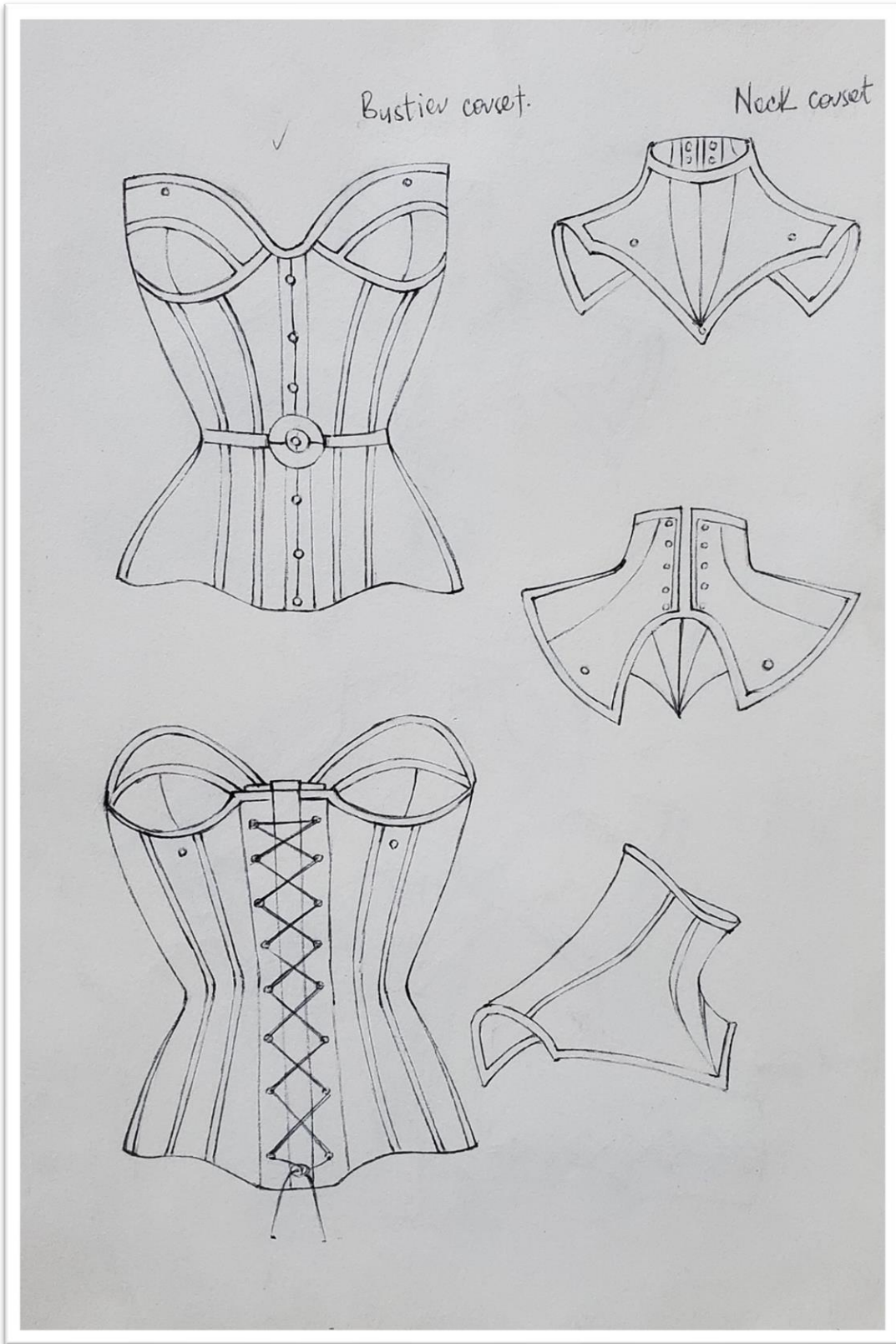

A design for a neck corset and arms armor.

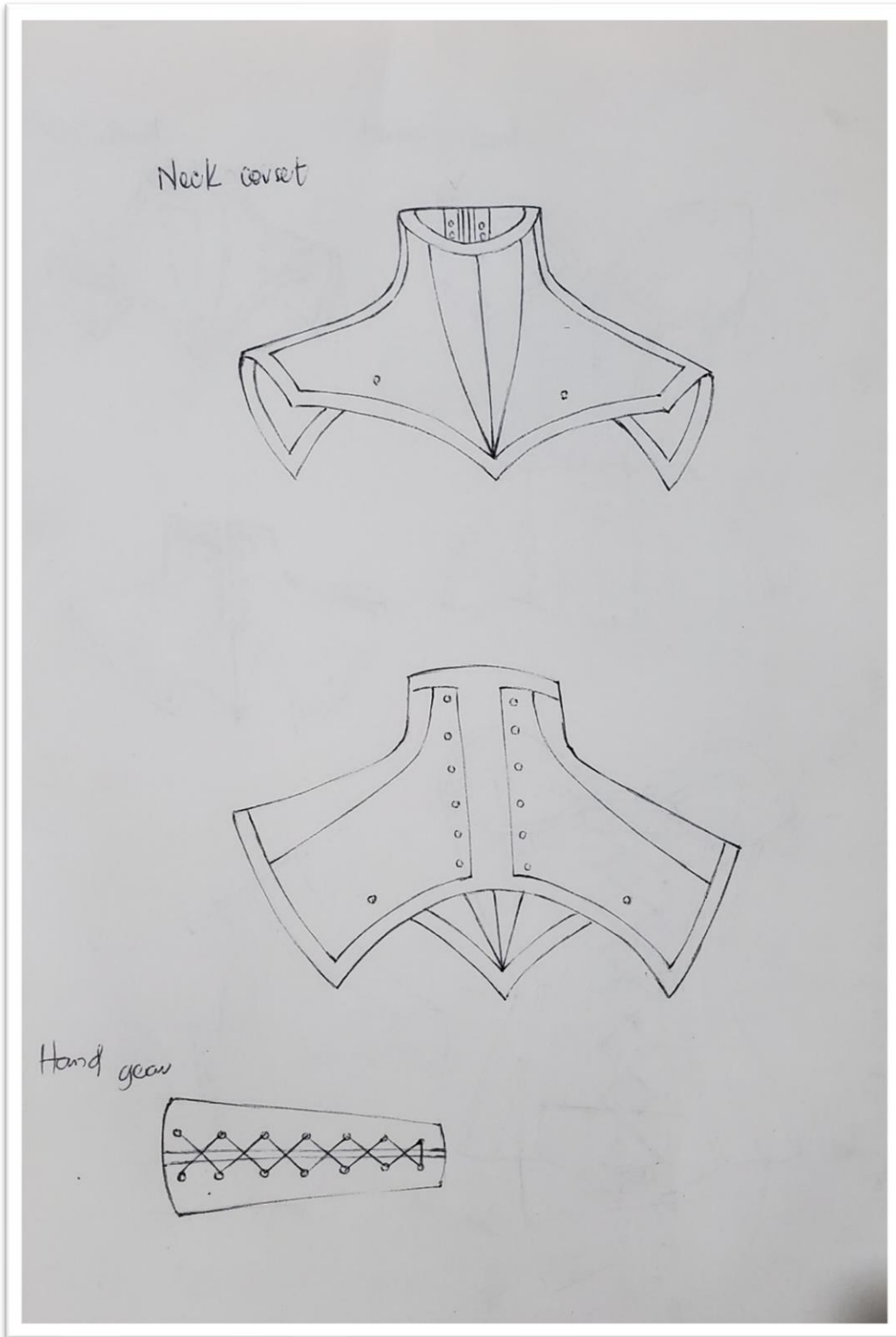

A design for a waist-hip bag.

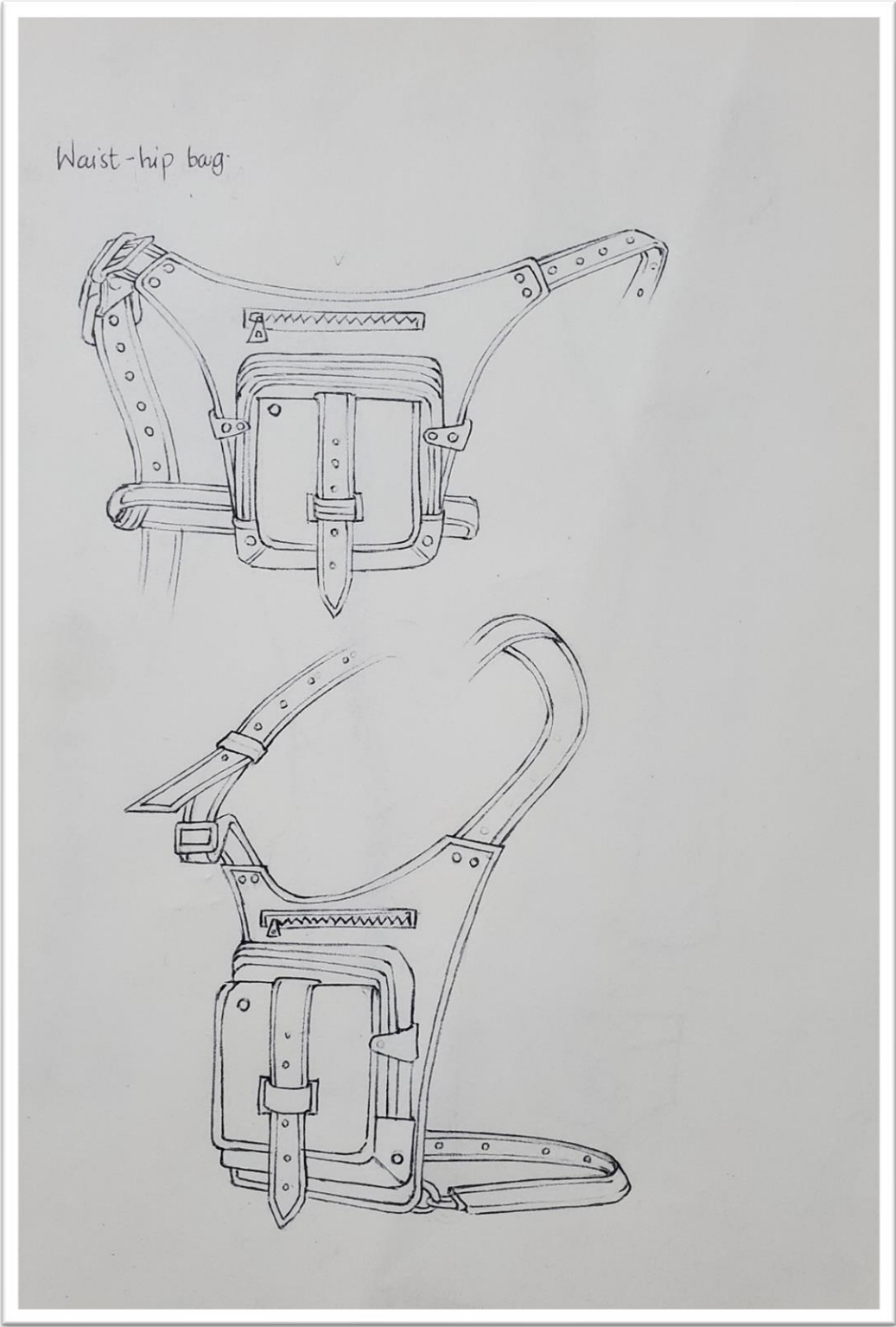

Trousseau design.

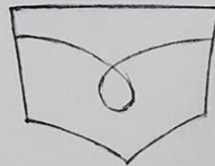
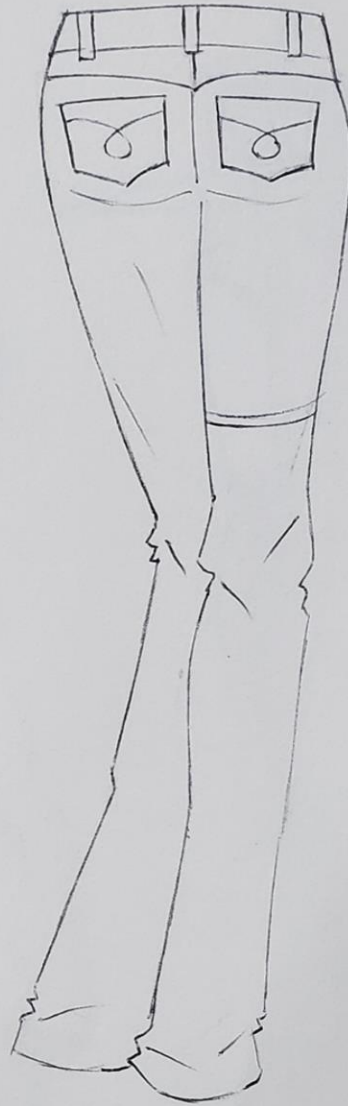
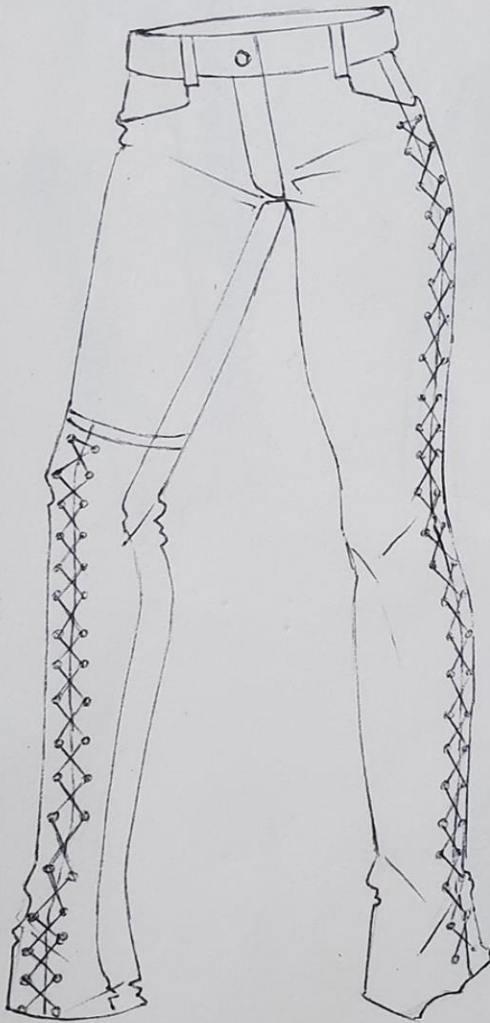

Technical sketches

NOTE: *all measurements are in inches.*

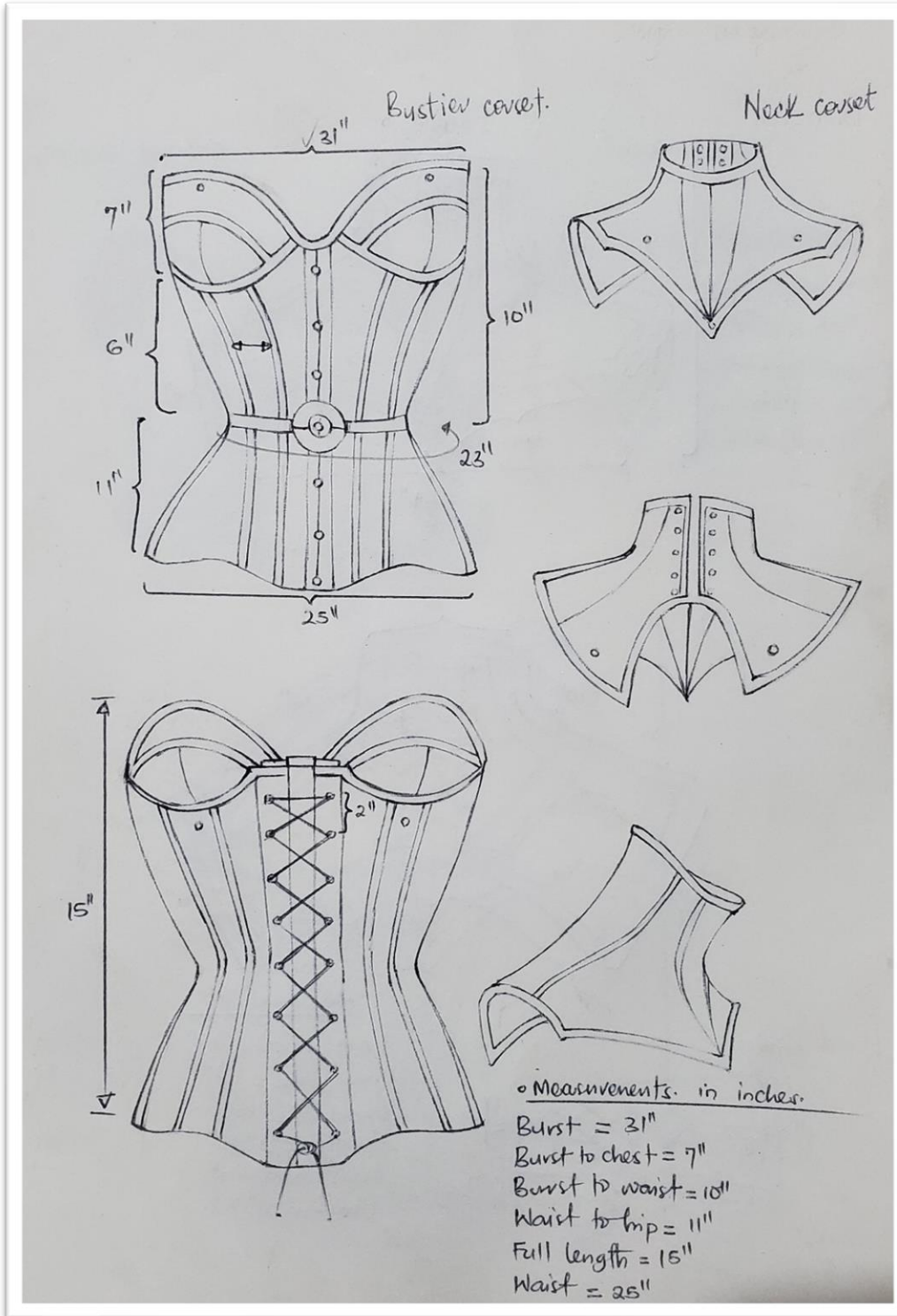

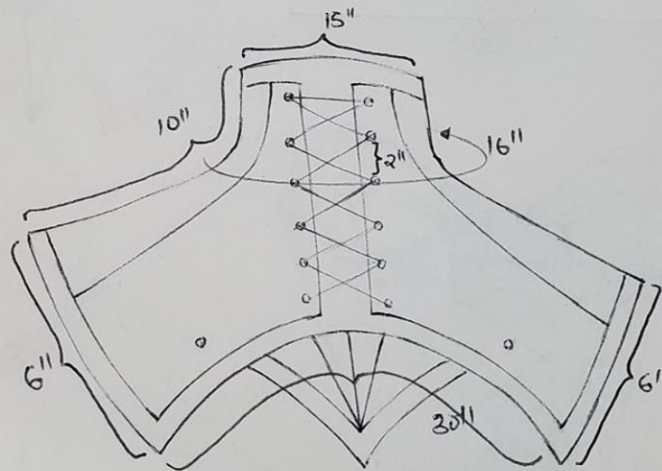
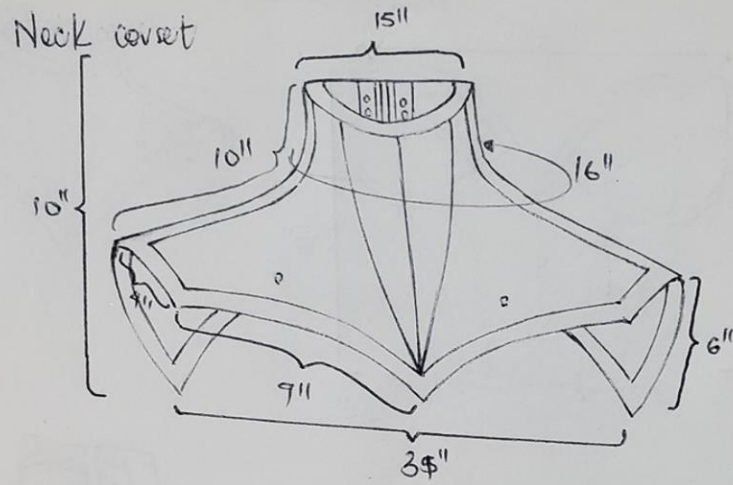

Measurements

- Neck width = 15"
- Inner nape = 16"
- Shoulder = 10"
- Bust = 31"
- Arm length = 9"
- Chest = 9" X 2

Hand gear

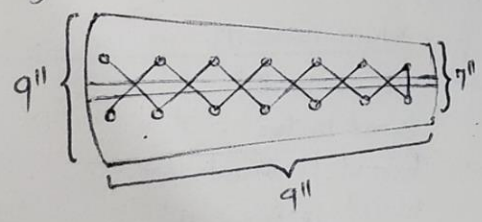

Waist-hip bag

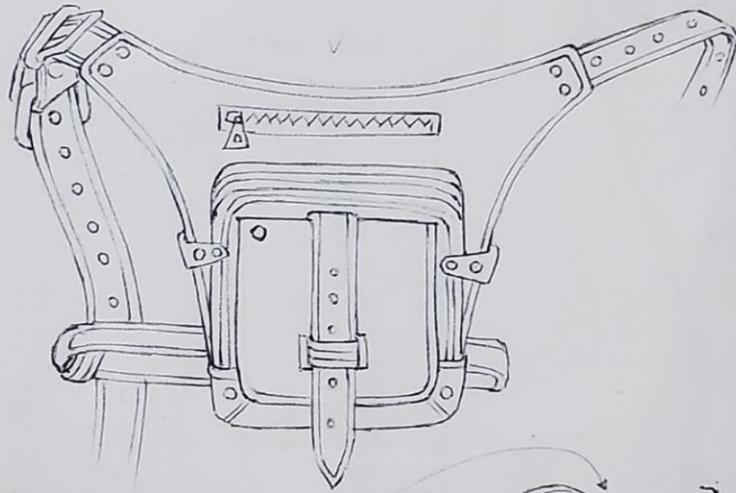

• Measurements

- Waist strap = 60"
- Hip strap = 45"
- outer small bag = 7"
- Bag width = 10"
- Full length = 13"

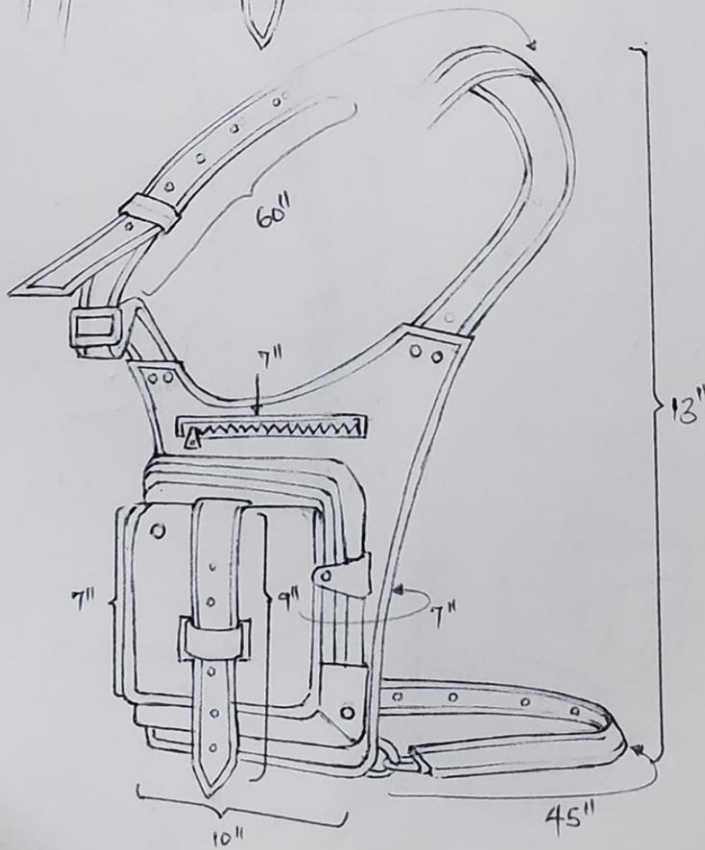

Trousers design.

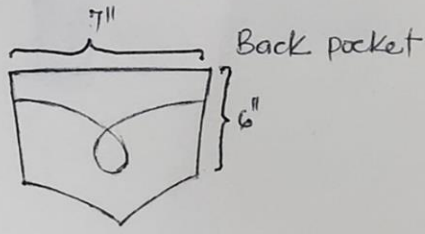
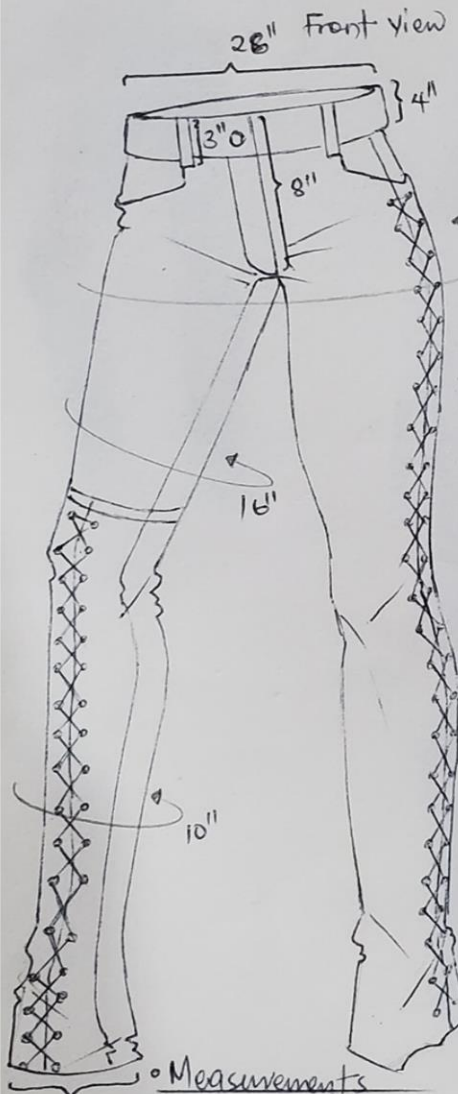

- Measurements
- 6" Full length = 38"
 - leg = 6"
 - calf = 10"
 - upper thigh = 16"
 - Waist = 26"
 - loop size = 3"
 - Hem = 2"

3 inches spacing of each eyelet gap.

Color development

I decided to choose brown for the final presentation because of the harsh conditions that the medieval people used to go through in terms of washing and sustainability to dirt.



Final Presentation

