

REAL LEATHER STAY DIFFERENT

2026

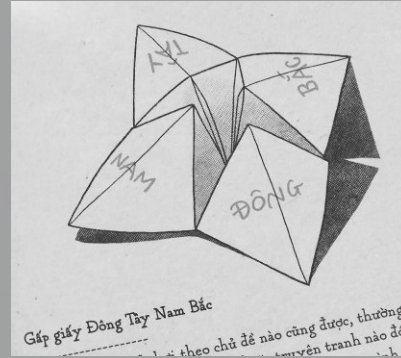

FORTUNA

Lover

DESIGNED BY:
KHANH LY NGO

TYPE :
APPAREL

ABOUT ME



HELLO REAL LEATHER, STAY DIFFERENT ,

I am Khánh Ly, a fashion student currently in my second year at Ho Chi Minh City University of Technology and Engineering. Throughout my studies and personal experimentation, I have worked on several small projects using leather, and over time, I have developed a strong appreciation for this material.

I have a strong fascination with form and pattern-cutting, seeing fabric manipulation as a way to explore new visual languages in fashion. Folds, modules, and interlocking structures not only create three-dimensional surfaces but also unlock transformative possibilities in garments. With each experiment, I aim to push the boundaries between technique, aesthetics, and wearability

My goal in participating in the Real Leader – Stay Different competition is to expand my knowledge, challenge myself in new ways, and embrace opportunities for growth in the future.

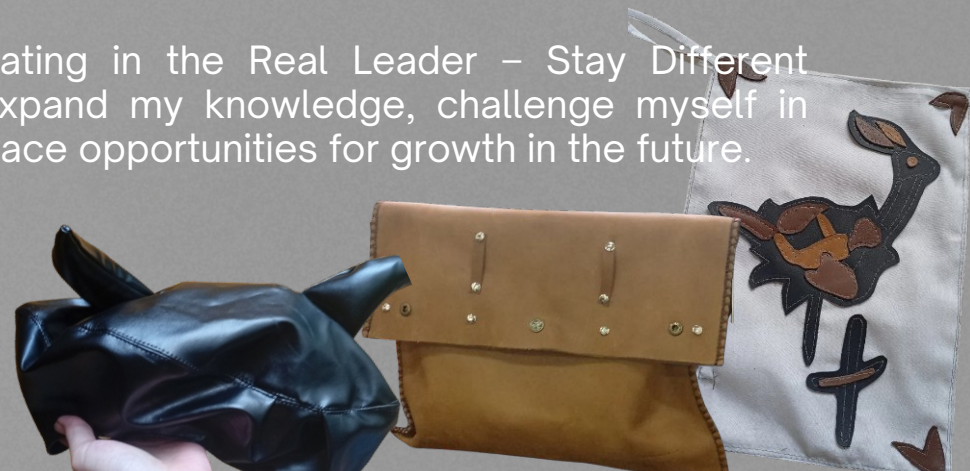

CONTENT

1. CUSTOMER

2. TREND

3. IDEA ANALYZE & MOODBOARD

4. SKETCH DEVELOPMENT

5. FLAT SKETCH

6. COLOR & MATERIAL

7. FUTURE DEVELOPMENT

TYPE :
APPAREL

DESIGNED BY:
KHANH LY NGO



BY:



CUSTOMER

TARGET CUSTOMER PROFILE

- Female, 18-30 years old, living in **Ho Chi Minh City, Hanoi, or Da Nang**, belonging to the urban youth group who love beauty and fashion.
- Occupation: **Creative arts student, marketing/PR employee, stylist, photographer, freelancer, content creator, micro-influencer.**
- Income: **8-35 million VND/month**; fashion expenses: **1-6 million VND/month**; preference for **value-for-money, durable, and versatile** items.
- **Hobbies:** Fashion, beauty, styling outfits, OOTD photography, attending workshops and exhibitions, searching for designs with stories and sustainable materials.
- **Personality:** Practical yet sophisticated; appreciates versatility, uniqueness, and just the right amount of personality; loves modular fashion.



TREND

THROUGH MY RESEARCH, I FOUND THAT JACKETS ARE THE MOST WIDELY PURCHASED AND WORN GARMENTS MADE FROM LEATHER, RANKING FIRST IN CONSUMER DEMAND. THIS INSIGHT FURTHER REINFORCES MY DECISION TO FOCUS ON JACKET DESIGN, AS IT OFFERS BOTH STRONG PRACTICAL VALUE AND HIGH COMMERCIAL POTENTIAL.

GLOBAL LEATHER JACKET TREND MAP 2026

Refined Minimalism & Hidden Seams	Architectural Forms & Origami Folding Techniques	Versatility & Modular Structure	Sustainable Materials & Artisanal Effects
<p>The market is shifting strongly towards "Refined Minimalism". Designs feature straight, seamless cuts and minimize metal hardware. The core silhouettes are funnel necks and leather blazers with hidden stitching, creating a luxurious and quiet aesthetic.</p>	<p>This is the intersection of fashion and architecture. Designers use folding techniques to create 3D blocks on the leather surface. These geometric folds not only create visual highlights but also shape the garment like a sculpture, reflecting the "Avant-Garde Functionalism" trend.</p>	<p>Transformable design trends are on the rise. Leather jackets are no longer static pieces; they can change shape through folds, expanding or contracting the hem. This meets the demand for interaction between the garment and the wearer (Interactive Fashion).</p>	<p>The rise of plant-based leather offers the ideal stiffness for memory folds. Combining this with artisanal surface treatments like patina polishing or distressed effects brings uniqueness and sustainability to high-end products.</p>

Introduce

FORTUNA

Trò chơi ĐÔNG TÂY NAM BẮC

I chose the 'East-West-South-North' origami fortune teller for the 'Fortuna' collection, as it symbolizes **luck** and **destiny**. Inspired by this childhood game, the apparel serves as a reminder that when we feel lost, we can pause, reflect, and cultivate our **inner strength**. Each fold represents a moment of mindfulness and **self-belief**, guiding us back to our true path in life.

Your breath
will smell like
farts

You will live
in a mansion

WE'RE GOING
ON HOLIDAY

GUESS

WHAT

colloid

DEEZ

SURPRISE

EDGE

VES

Fortune
teller
Surprise!

☆ HOW TO PLAY ☆

- 1 PLACE THUMB AND INDEX FINGERS AND THE FOUR CORNERS AND SQUEEZE THEM OVER, IF MAKES THE FORTUNE TELLER SHAPE
- 2 PICK ONE OF THE WORDS ON THE TOP "GUESS" - "WHAT" - "DEEZ" - "SURPRISE" SPELL THEM OUT WHILE MOVING THE FORTUNE TELLER "IN AND OUT"
- 3 LAYING ON THE INSIDE WORDS SELECT AN INSIDE WORD AND SPELL THE WORD MOVING THE FORTUNE TELLER "IN AND OUT"
- 4 SELECT ONE OF THE INSIDE WORDS AND LIFT THE PANEL UP TO REVEAL YOUR SURPRISE!

have fun ..

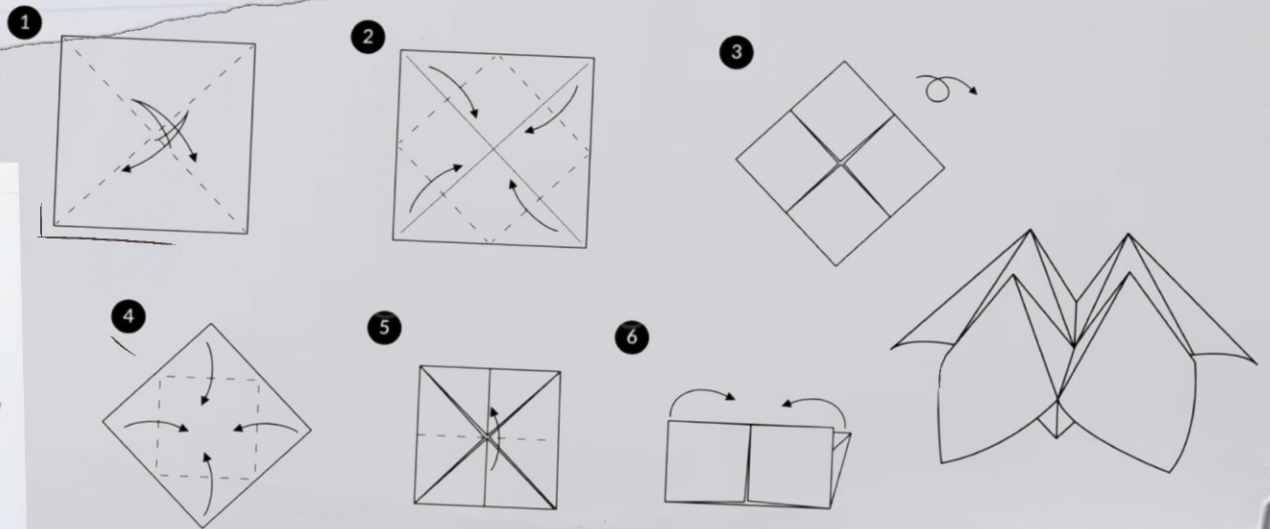

about it, the contrary; but if it
quite at the bottom, then the mar
place. A leaf of clover, or tre
denoting, if at the top of the cup,
H 2

#Craft/ Notebook paper

#Top-down view

#Crease pattern (nếp gấp)

#Cardinal directions

#How to make

#DIY craft

#Nostalgia

STORY TELLING

The “**Đông-Tây-Nam-Bắc**” paper-folding game is actually a simple origami-based fortune-telling toy, known in English as a **paper fortune teller** or **cootie catcher**. While origami originated in East Asia, the “fortune teller” form itself appeared in 19th-century Europe as a small paper container and later became a popular prediction game across the West by the mid-20th century. When it reached Vietnam, it evolved into the familiar **Đông-Tây-Nam-Bắc** paper toy and gradually became a **handmade childhood memory** of mine.



IDEA ANALYZE

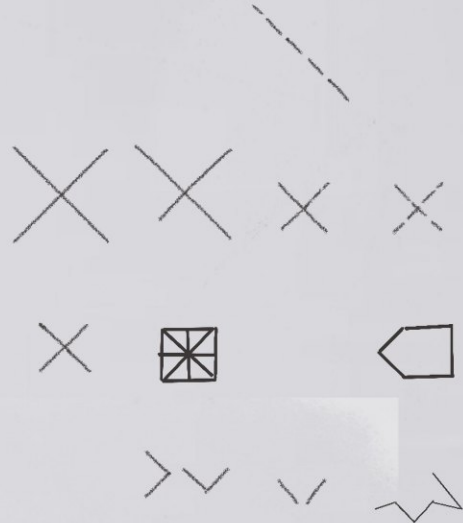
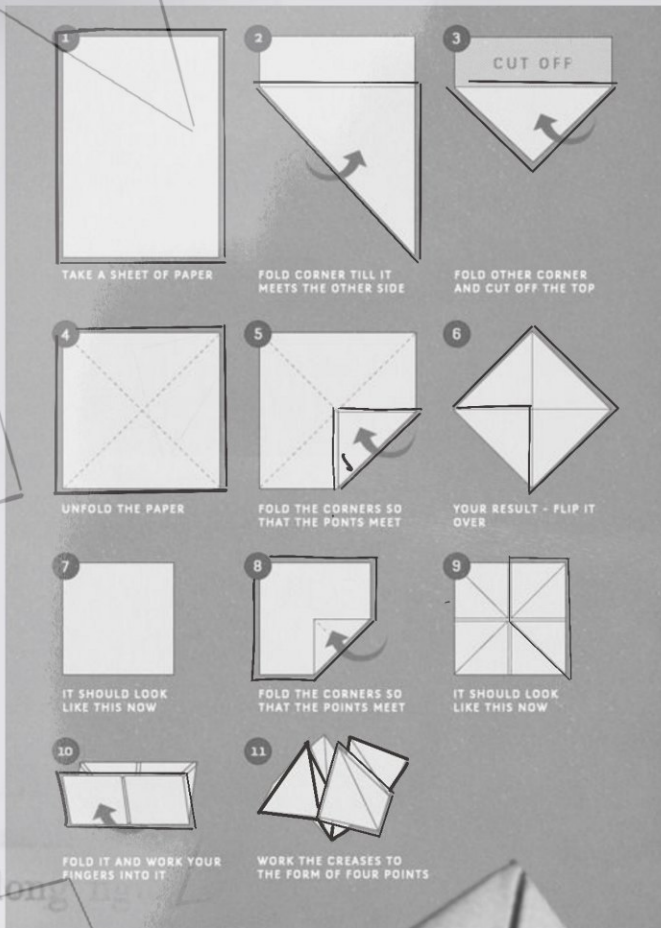

#Symmetry (đối xứng)

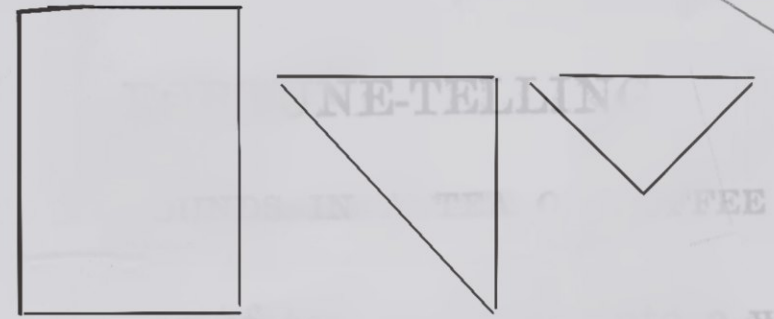
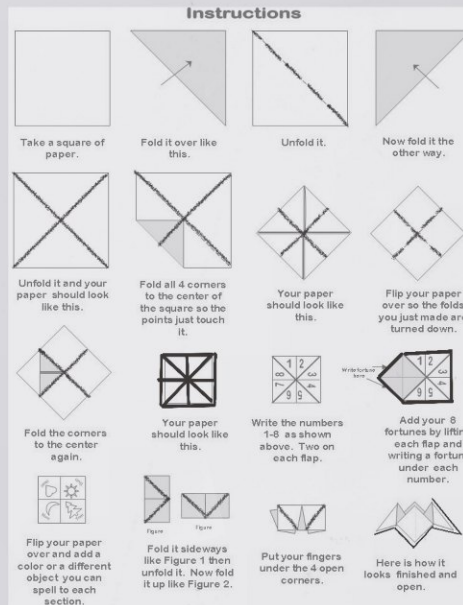

#Geometric folding (gấp hình học)



#Origami

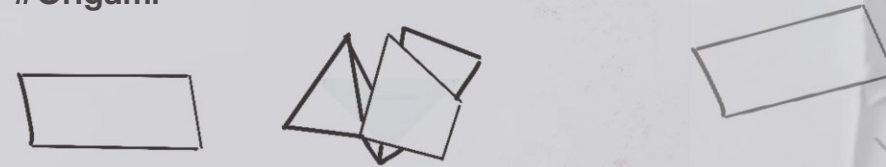

I incorporated the **folding lines** from the paper-folding steps and translated them into the **silhouette** of the garment.



N

W

Fortuna

FIRST SKETCH DEVELOPMENT

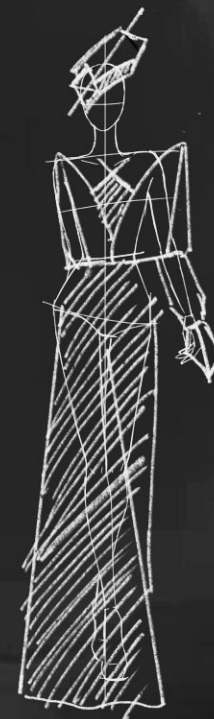
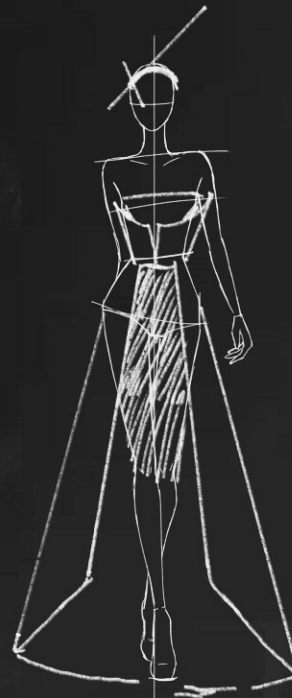
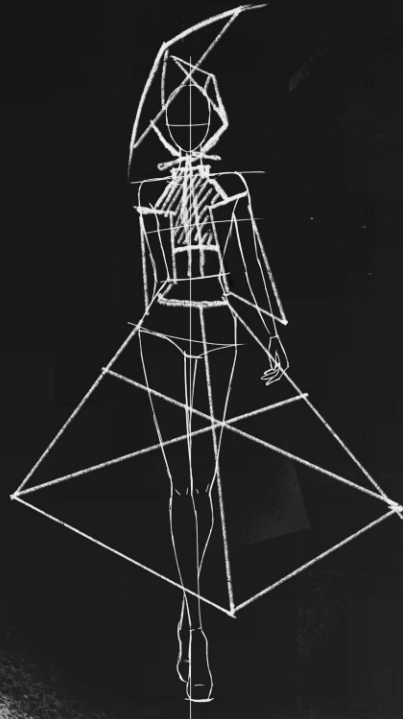
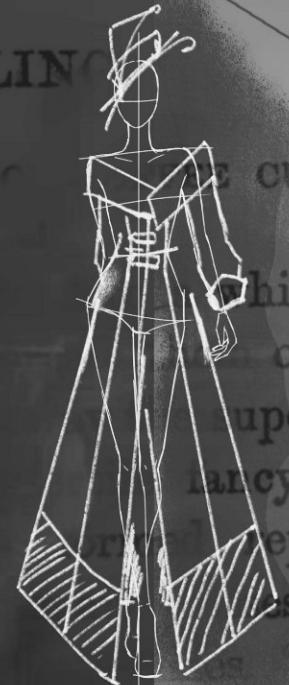
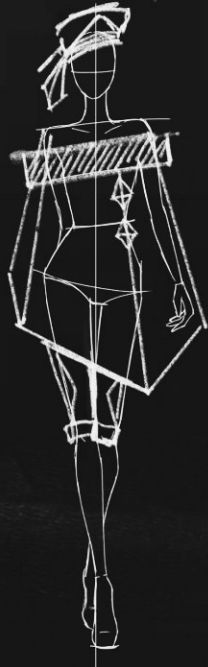

NE-TELLING

TEA C

CUP,
white
over
super
lancy in
pres
s—t
ra
lity.

ro
l be
; oblong
sted, or
and annoy
etermined
honour; a
if a letter can
ntiel of the name
in the clear part
on; if clouds are
uld chance to be
ge will never take

SKETCH



FABRIC MANIPULATING



- MODULAR DESIGN

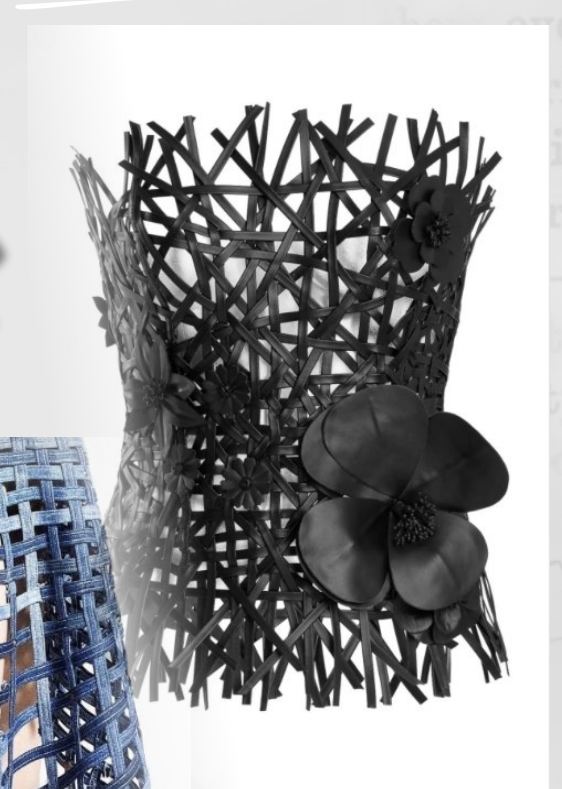

- REPETITION & PATTERN SYSTEM



- WEAVING / LATTICE STRUCTURE

SECOND SKETCH DEVELOPMENT

After further discussion and alignment with my supervising lecturer, I have refined the development direction of the outfit. To enhance wearability and commercial potential, the jacket design has been brought back to a basic form with a minimalist color palette. Instead of expressing the concept mainly through surface decoration, the focus has been shifted to the garment's structural design, allowing the concept to be conveyed in a clear, streamlined, and effective way while still maintaining commercial appeal.

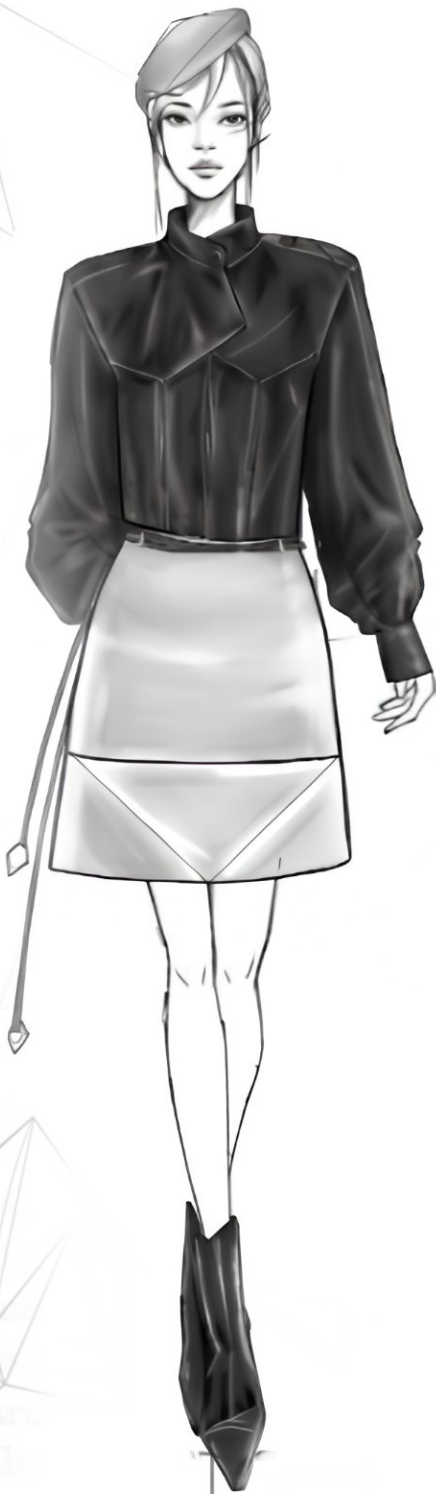

REAL LEATHER STAY DIFFERENT

COLOR & MATERIAL

2026



I-GOBI (Black 8)



**I-CHARMING
LINNING (Pink salt)**



I-CHARADE (White 4)



I-RED 5



#4A4646



#B5B0B0

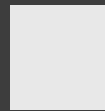

#E8E8E8



#81221E

DESIGNED BY:
KHANH LY NGO

TYPE :
APPAREL

SKETCHNOTE

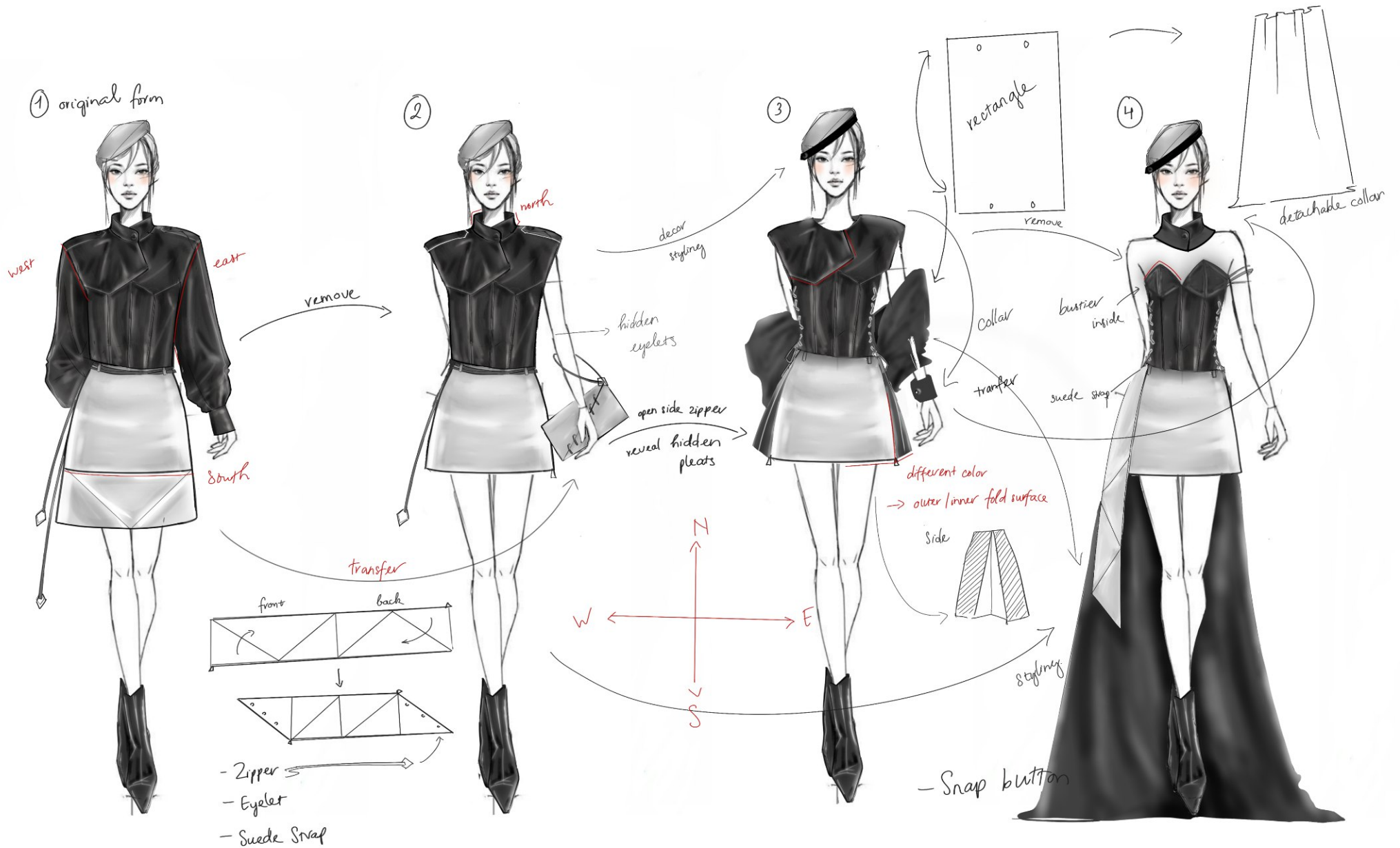

FINAL SKETCH



SEASON	F/W 26/27	STYLE NO.		CATEGORY	Apparel	FABRIC	Leather	DATE	20/05/26
BRAND	Lyer	NAME	Module Jacket		SIZE	S			

SPEC SHEET

SIZE SPEC					
A	Center Back Length	40			
B	Chest	88			
C	Shoulder	40			
D	Waist				
E	Bottom	68			
F	Sleeve Length	50			
G	Armhole	42			
H	Muscle				
I	Cuff Opening	25			
J	Neck Width	40			
K	Front Neck Drop	8			
L	Back Neck Drop	2			
M	Neck Rib Width				
N	Cuff Rib Height				
O	Bottom Rib Height				
P	Manchette	12			
Q		16			

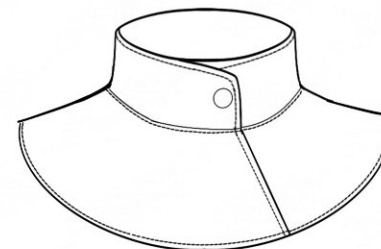
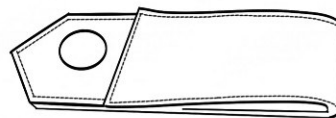
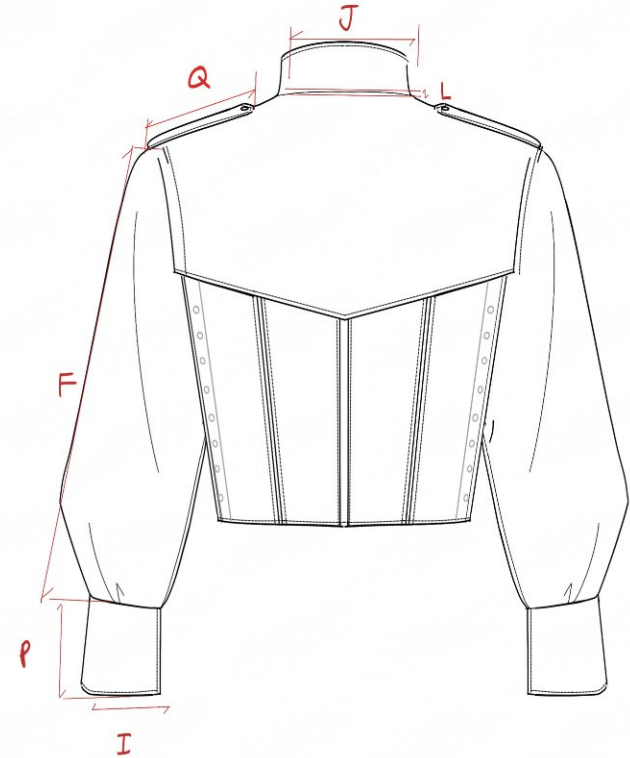
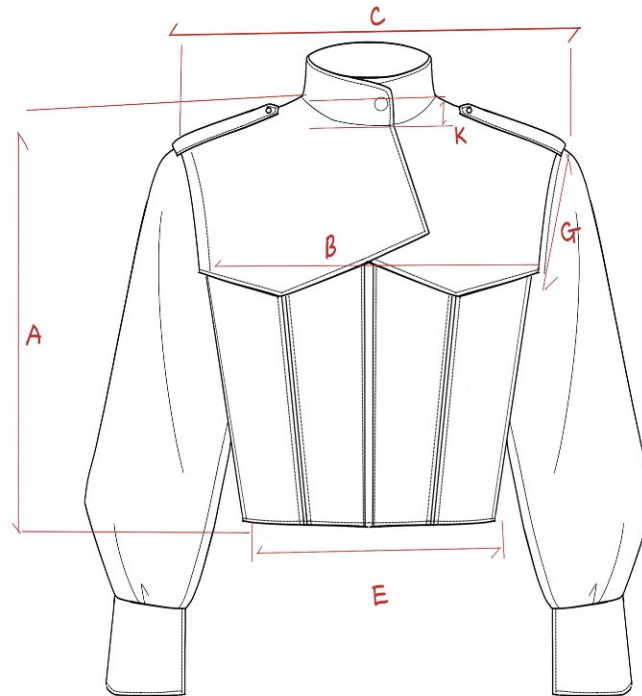

I-GOBI (Black 8)



#404040

FLATSKETCH

SEASON	F/W 26/27	STYLE NO.		CATEGORY	Apparel	FABRIC	Leather	DATE	05/2026
BRAND	Lyver	NAME	Module skirt		SIZE	S			

SPEC SHEET

SIZE SPEC					
A	WAIST	64			
B	LENGTH	37			
C	INSEAM				
D	HIP	90			
E	WITH ACROSS CROTCH				
F	THIGH				
G	KNEE				
H	LEG OPENING				
I	FRONT RISE				
J	BACK RISE				
K	WAISTBAND WIDTH				
L	POCKET OPENING				
M	POCKET POSITION				
N		96			
O		102			
P	length detachable dress	10			
Q					

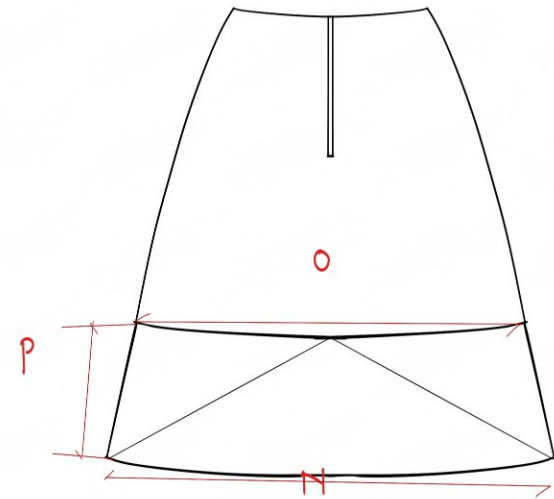
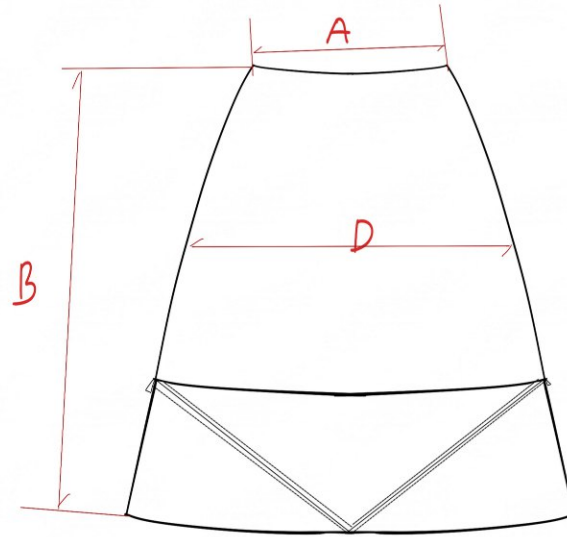

I-CHARADE (White 4)



#E8E8E8

FLATSKETCH

SEASON	F/W 26/27	STYLE NO.		CATEGORY	Apparel	FABRIC	Leather	DATE	20/05/26
BRAND	Lyver	NAME	Split skirt			SIZE	S		

SPEC SHEET

SIZE SPEC					
A	WAIST	40			
B	LENGTH	110			
C	INSEAM				
D	HIP				
E	WITH ACROSS CROTCH				
F	THIGH				
G	KNEE				
H	LEG OPENING				
I	FRONT RISE				
J	BACK RISE				
K	WAISTBAND WIDTH				
L	POCKET OPENING				
M	POCKET POSITION				
N	—	30			
O	—	60			
P					
Q					

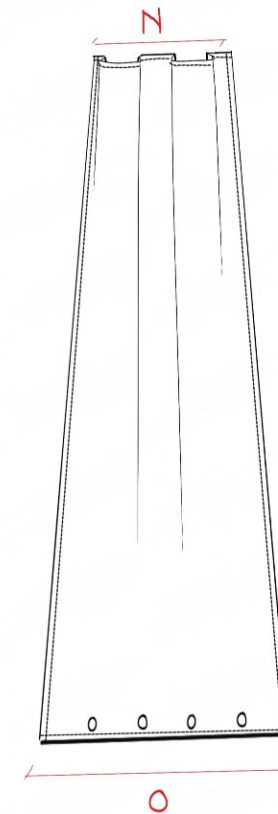

I-GOBI (Black 8)



#404040



FUTURE DEVELOPMENT

REUSE	RECYCLE	END-OF-LIFE	FUTURE GROWTH
<ul style="list-style-type: none">• Four-direction modular folding enables rotation and transformation (coat-dress)• Detachable structure extends product lifespan.• Replaceable modules allow continuous upgrading (upcycle).	<ul style="list-style-type: none">• Folded panels can be recycled into new materials or accessories.• Modular parts enable partial recycling.• Scrap materials reused as small components.	<ul style="list-style-type: none">• Repair or replace modules instead of discarding.• Take-back system creates a closed loop.• Material separation for efficient recycling.	<ul style="list-style-type: none">• Expand modular system based on four directions.• Apply advanced 3D folding technology.• Personalization based on user identity.• Position Vietnamese design globally.

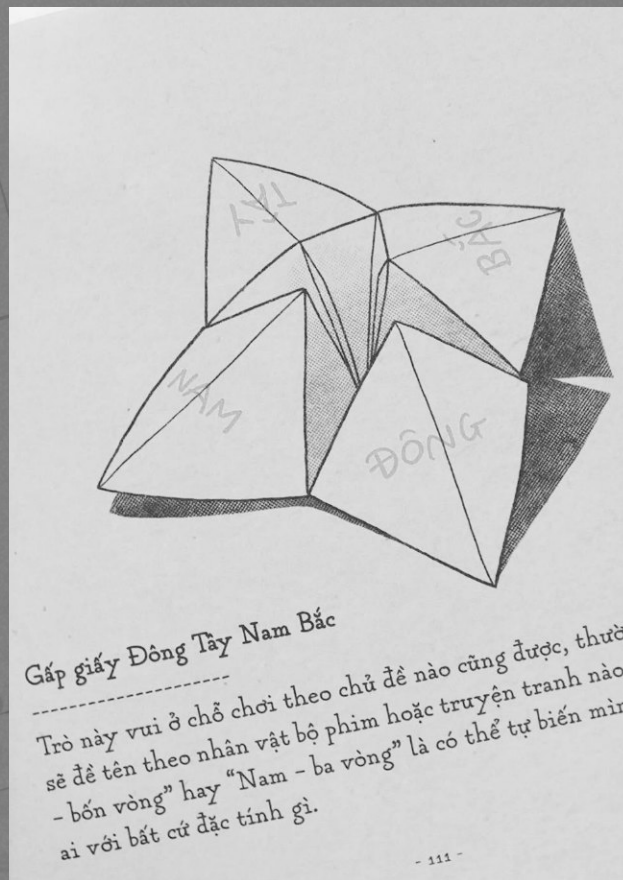

THANK YOU

Thank you for taking the time to explore my entry, and thank you REAL LEATHER STAY DIFFERENT for creating this exciting contest that gave me the opportunity to challenge myself. I hope the contest will be able to grow even more in the future.

by Kcy_Ngo

DESIGNED BY:
KHANH LY NGO

TYPE :
APPAREL