



CĀ MĒN

PHẠM KHANH LINH

REAL LEATHER. STAY DIFFERENT - ACCESSORIES DESIGN

CÀ MÈN

CONCEPT MOODBOARD

PHẠM KHANH LINH - ACCESSORIES DESIGN

Cà Mèn, named after the **Vietnamese tiffin box** — a word borrowed from the French gamelle, carried across a century and made entirely Vietnamese.

During the bao cấp years, the cà mèn was part of **everyday life**. Office workers brought it to work. Teachers shared it with students. Mothers packed it before dawn and sent it out into the city on the back of a bicycle. **Small, stackable, tied together** with whatever was available. It held rice, broth, pickled vegetables — and underneath all of that, it held **care**.

This bag is designed from that same feeling. Structured and layered, with the **tactile honesty** like enamel and worn metal. It tries to be **useful, familiar, warm** — the kind of object you reach for without thinking, because it has always been there.



CĀ MĒN

COLORS & TEXTILES

PHẠM KHANH LINH - ACCESSORIES DESIGN



CĀ MĒN

DESIGN DEVELOPMENT

PHẠM KHANH LINH - ACCESSORIES DESIGN

Inspired by the stacked and **compartmentalized nature** of the tiffin box, I designed the bag with this concept in mind, exploring how it can **change its form and functionality** by adding or removing tiers. This structure is achieved through the use of a calculated network of clasps, which can be interchangeably connected to one another. In this way, the design becomes more **versatile and multi-purpose**, ultimately contributing to a more sustainable approach.

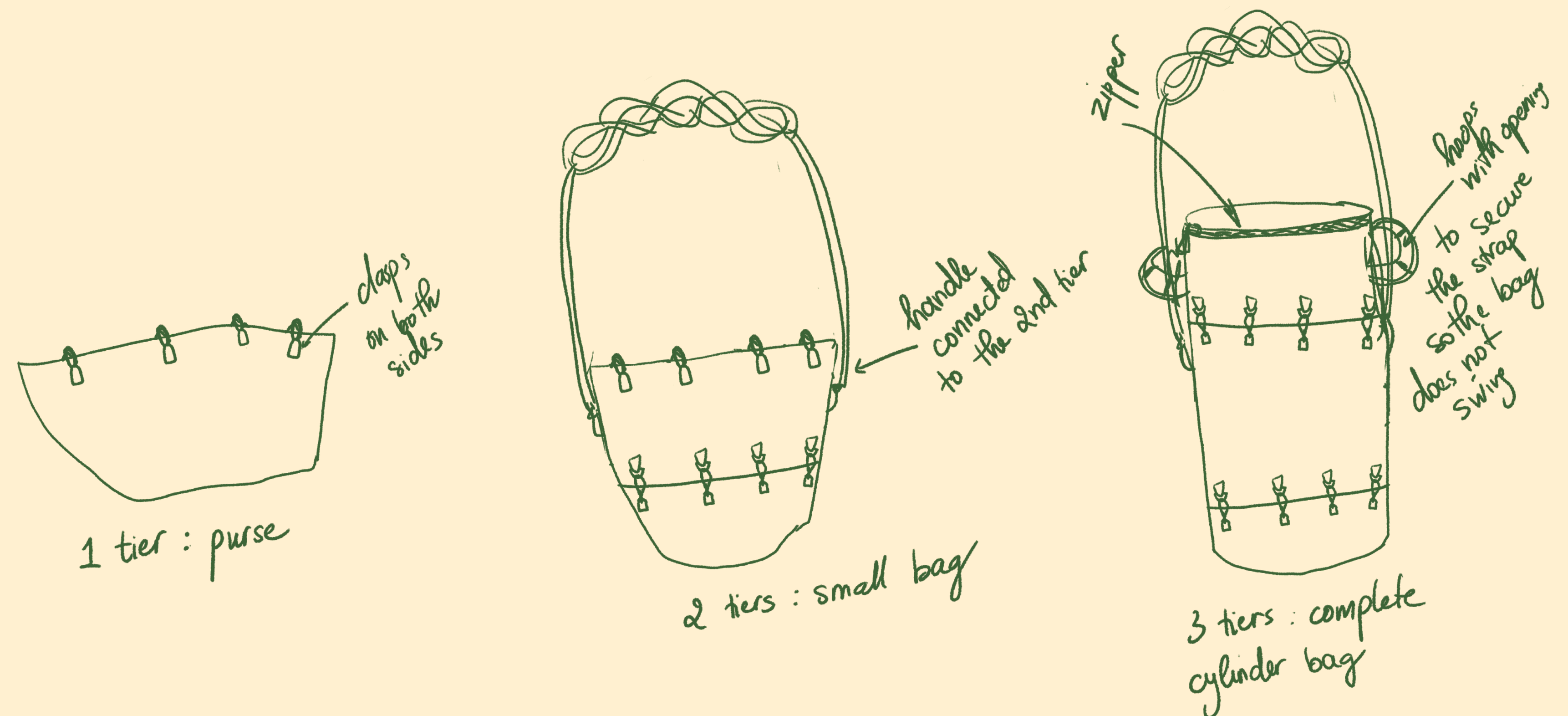

CĀ MĒN

ILLUSTRATION

PHẠM KHANH LINH - ACCESSORIES DESIGN

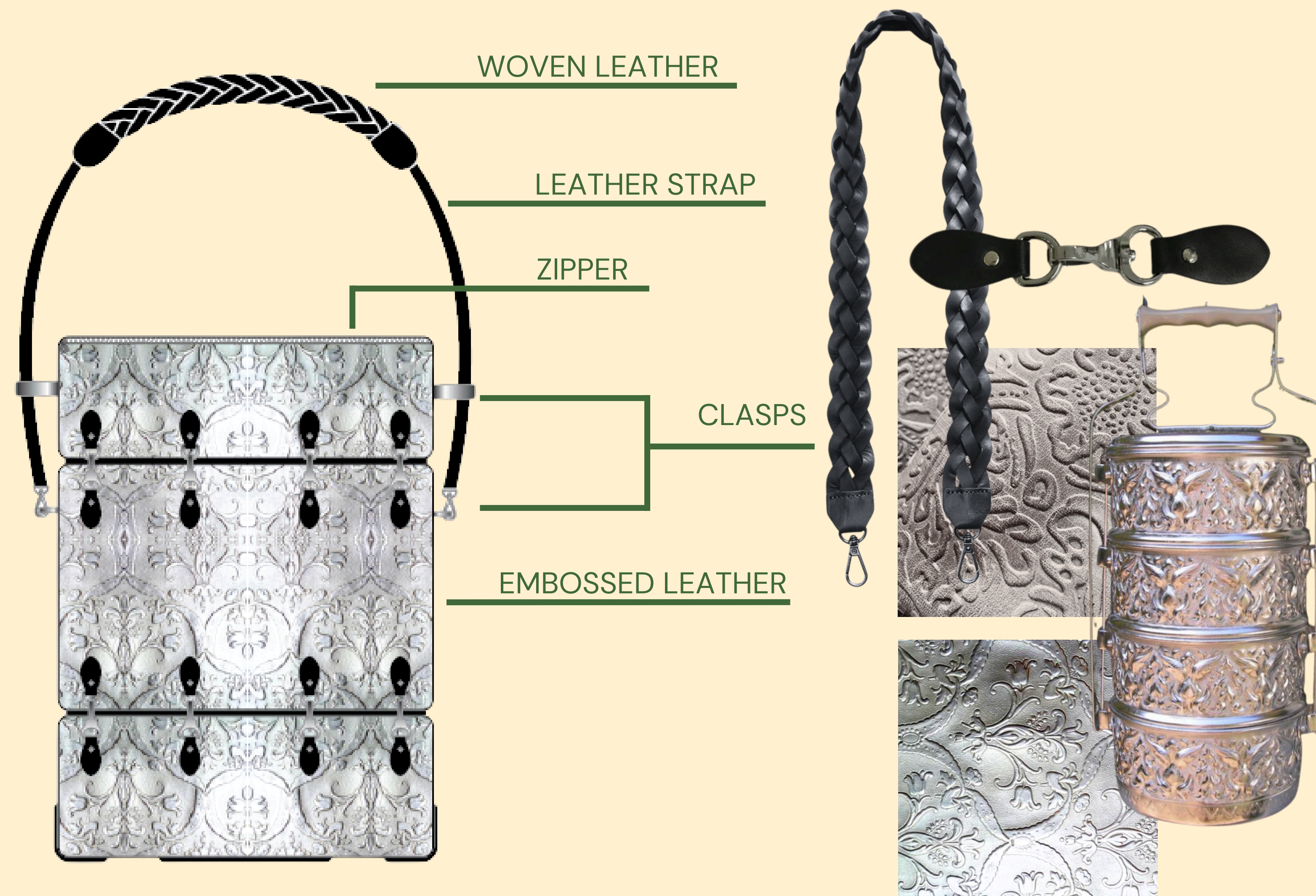

ILLUSTRATION

CĀ MĒN

TECHNICAL DRAWING & MEASUREMENTS

PHẠM KHANH LINH - ACCESSORIES DESIGN

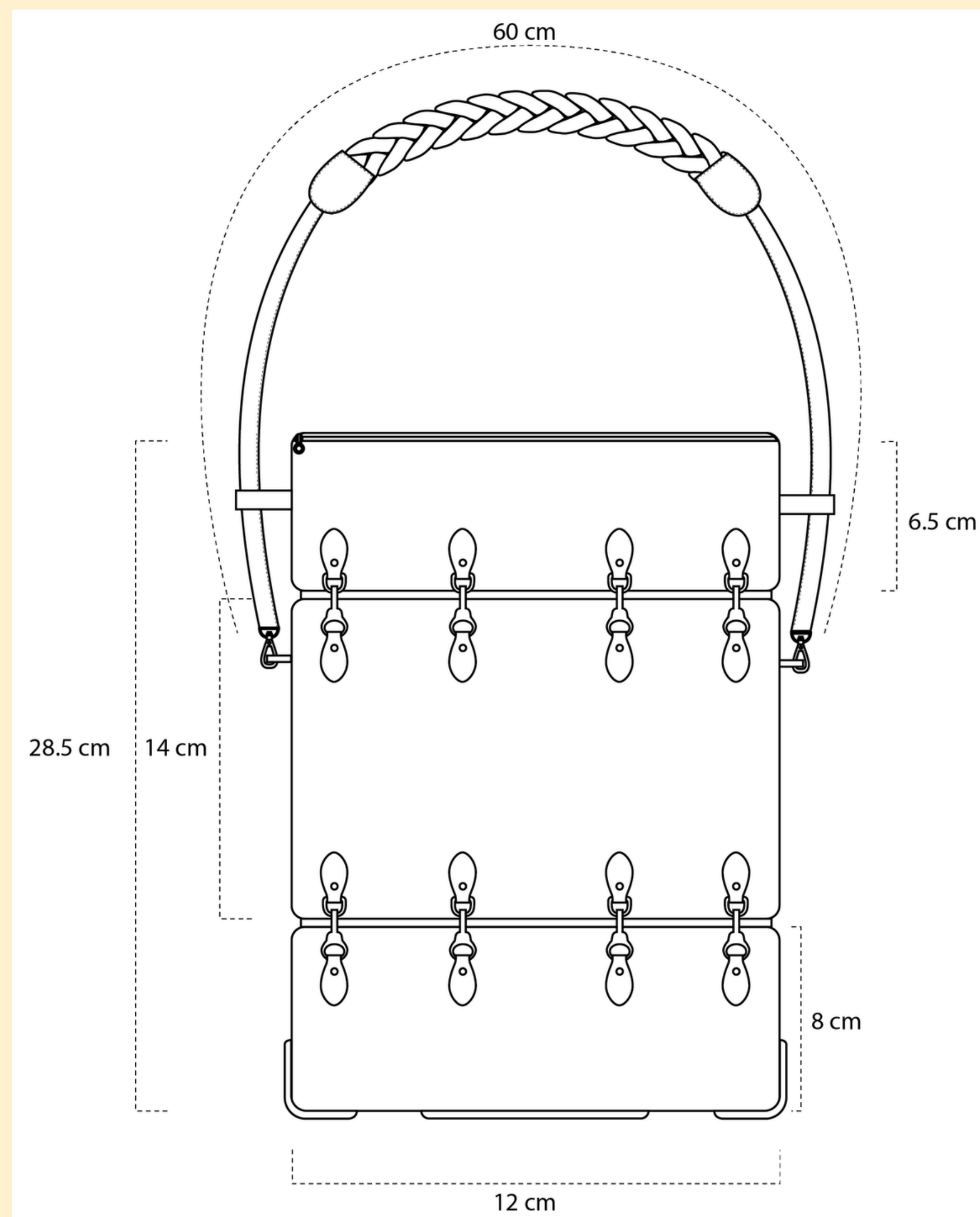

MEASUREMENTS

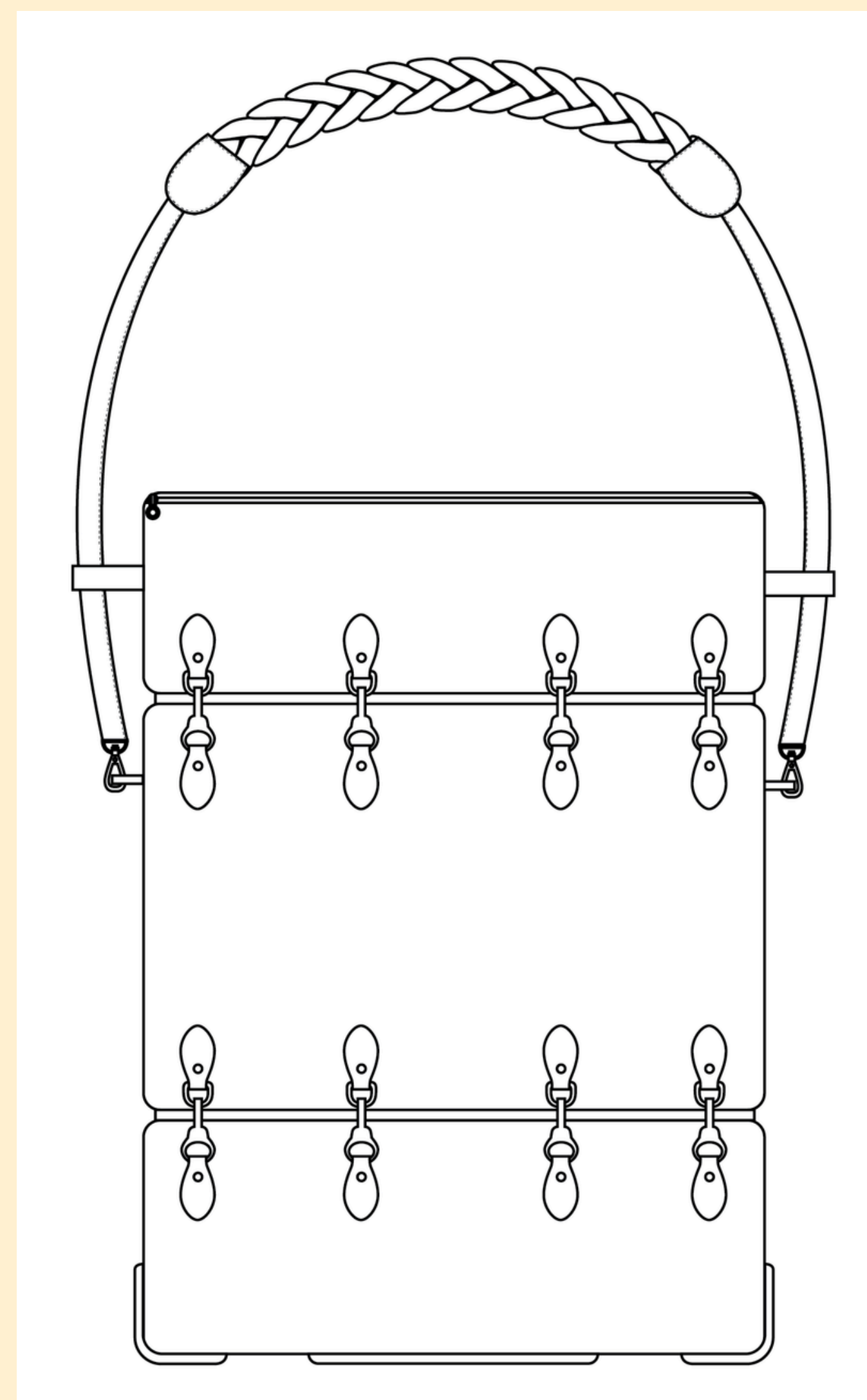

FRONT

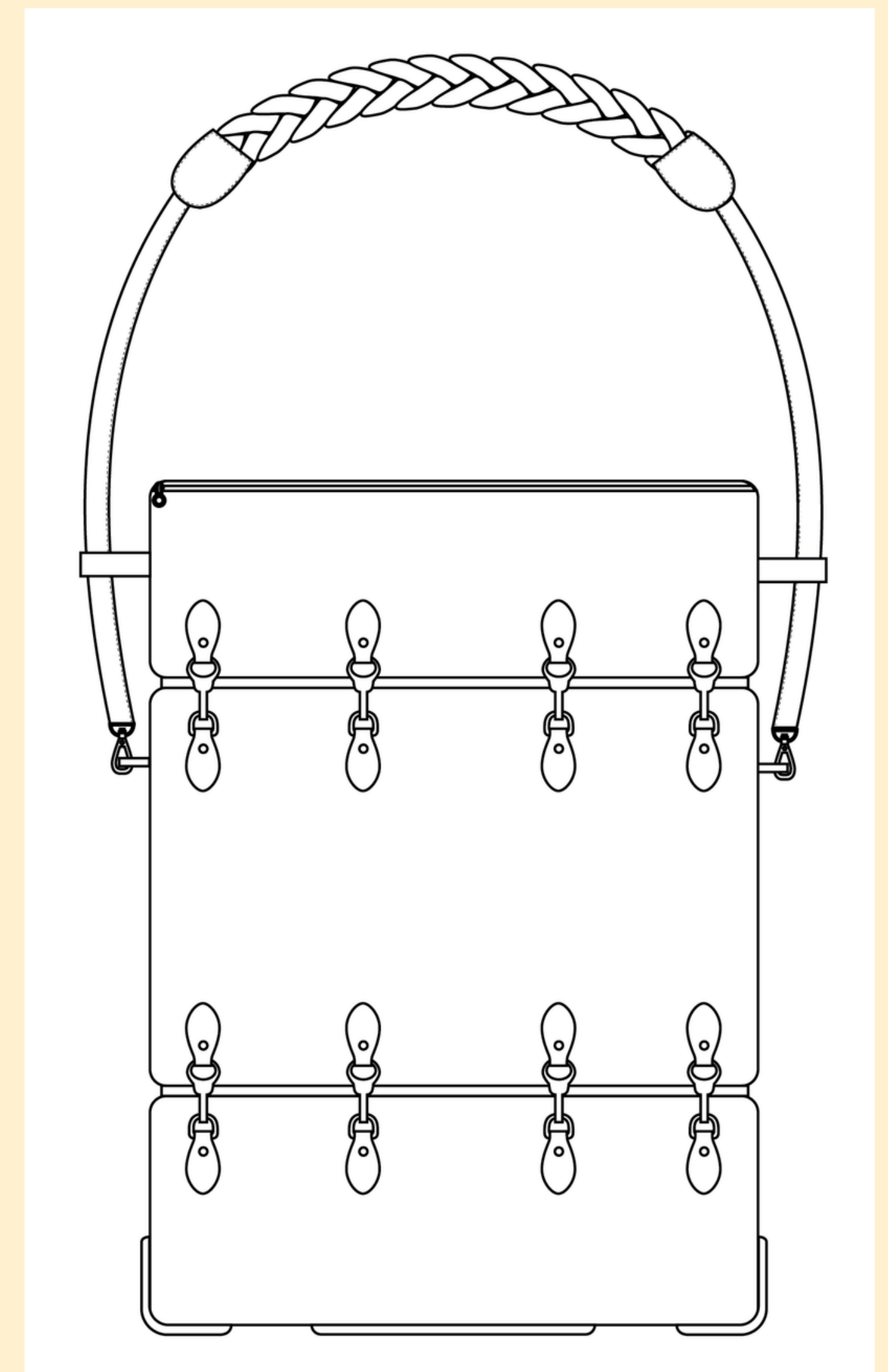

BACK

THANK YOU!