

# IONEER

Seem changed, same soul

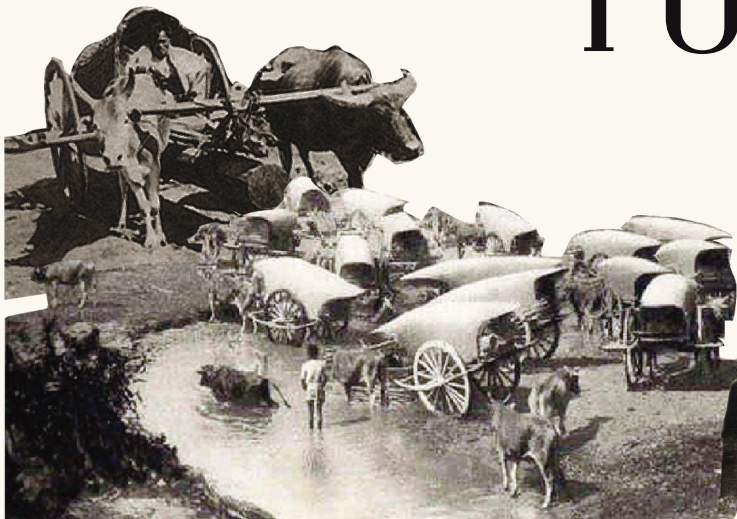

# NAI HOI (N.)

/nai hɔi/

"Nai Hoi" named as leader of caravan  
in Northeast Thailand

In an era when long-distance travel by train was impossible in Thailand, a caravan group served this purpose, embarking on journeys with their oxen. These individuals, known as "Nai Hoi" were oxen herders.

"Nai Hoi" named as leader of caravan in Northeast (Isan), in the Isan dialect refers to the oxen's caretaker. The word "Hoi" comes from the Thai word "Roi" in central region meaning "to string together." When a Nai Hoi went on a trade, they would fill bags of coins, called "Thung Tai" (traditional redemption bags), and then string these bags together into garlands, sometimes worn on the arm or around the waist.

Nai Hoi were skilled navigators, leaders who guided caravans to their destinations, overcoming numerous obstacles along the way.

As times changed, the profession of Nai Hoi disappeared. However, the way of life—traveling and meticulously collecting valuable experiences—remained unchanged.

It's the same with people nowadays. Each of us is a leader in our own field, possessing expertise, leading ourselves and those behind us to the highest achievements. This bag aims to be a companion on your journey, allowing you to collect and reassemble valuable memories, both tangible and intangible, preserving precious moments and experiences by each of your journey. Accompanied by companions since ancient times, such as cowhide leather, large animals that were considered valuable assets. As the way of life of the cattle trader, whose essence remains even time passes.





Ticket To  
Anywhere

146017

Journey

Wise

Lead your own rythm

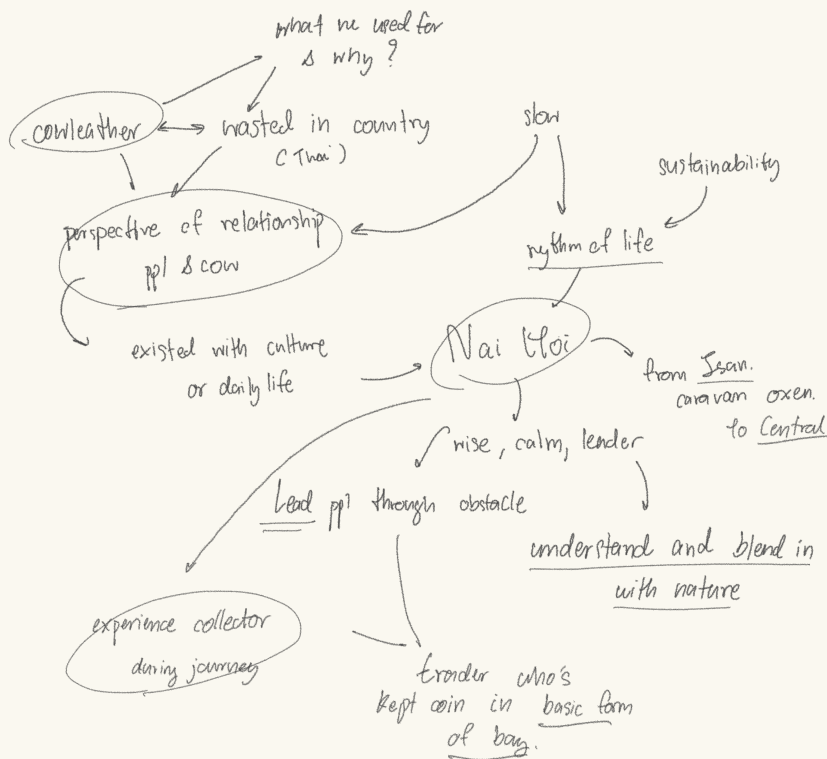

key words.

- Lead and bring ppl beside.
- collector
- feel nature.

①



ស្រទាប់  
ឈាម

②

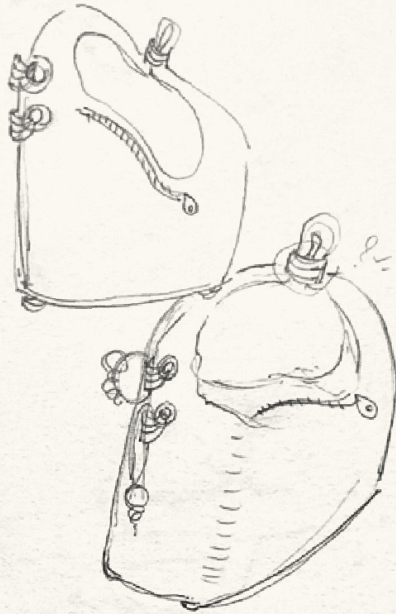

③



chan



sketch



develop



F I N A L

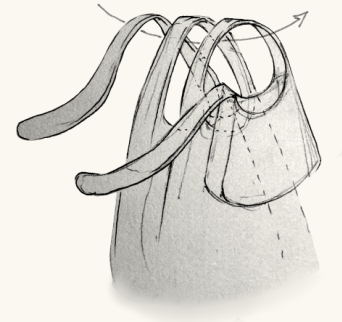
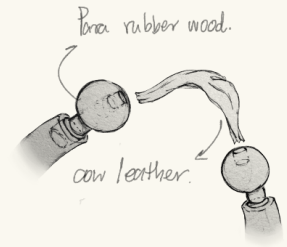

# DESIGN

Handle part of this piece is inspired by septum piercing jewelry, drawing a parallel to the way Nai Hoi leads their oxen using ropes attached to the septum of the animals' noses. This suggests that when guiding someone or something along a path, there exists a mutual reliance on one another's benefits and well-being.

The leather that connects in the center absorbs the force from the ground. This design ensures that the shoulder feels comfortable when wearing it.

Three bags that have connected strap was inspired by word "Roi." The reasons were to make all size of bags that build for each desire "String together".

The design of bags is essential for convenience and efficiency during travel. When Nai Hoi embarks on a journey, bags should assist in easily collecting vulnerable items. All designs initially center around the form that most people associate with "Thung," before evolving through geometric shapes then developed using geometric shapes to minimize the carbon footprint in the manufacturing process, while also being user-friendly for a modern lifestyle, especially when carrying multiple items.

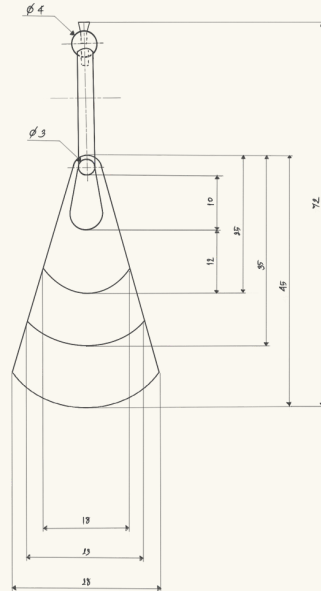
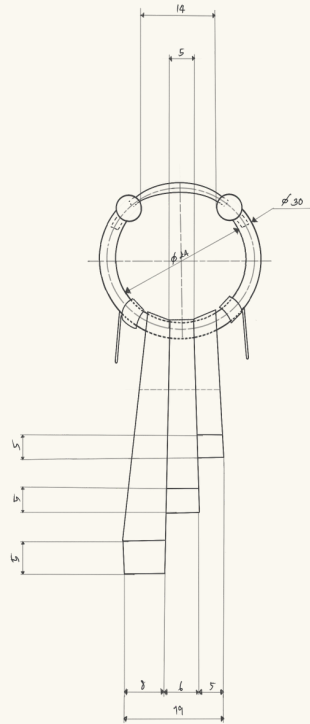

UNIT

CM

## Leather



Cellulose Board is made from recycled paper and plant waste, helping to reduce deforestation and waste. Its production involves low energy consumption and it acts as a carbon storage, without emitting any chemical toxins.

Cellulose board

## Rubberwood Scraps

Para rubberwood is a sustainable choice. After 25 to 30 years, trees stop producing latex and are harvested for wood, making efficient use of resources. This durable wood is ideal for furniture and flooring. Replacing harvested trees supports reforestation and benefits the local economy.

## linen black textile

Linen is made from flax, a hardy plant that grows with minimal water and no harmful chemicals. Unlike polyester, every part of the flax plant is used during production, and the final fabric is 100% biodegradable. Because linen is exceptionally strong and naturally resists bacteria, it extends the lifespan of the bag without shedding toxic microplastics into the environment.

Magnetic Snaps with Washer







# IONEER

Ralida  
Pasunnajit